

MiKE INTERiÖR
ALLT INOM OFFENTLIG MILJÖ

bé'

Life
Style

Style Culture since 1967

BELTÁ Lifestyle

Born through the desire of combining design and innovation, Beltá has quickly become a active player for the vanguard furniture field in national and international markets.

We create singular and unique objects. Objects that were created to excite the mind and fulfil the functions for which they were designed. Beltá designs physical products and gives them soul and spirit. In its passion for design, the company works with international designers.

Our productive processes have the most advanced manufacturing tradition that we join with our tradition craft to obtain the optimum quality in our models. We are certificated by the demanding quality regulation of ISO 9001.

Beltá is committed to maintain a sustainable and environmentally friendly community. We invest in research in order to obtain materials and processes creating efficiency and effectiveness. A part of our resources are devoted to projects for social purposes.

Because of the quality of our products, its excellent and awarded design and the commercial and logistical network of the company; Beltá in present is in more than 30 countries with sustained growth every year due in part to the working with the last distribution and product sales technologies. We are a company leader in the furniture field expanding within the global market place.

BELTÁ Estilo de Vida

Nacida del deseo de apostar firmemente por el diseño y la innovación, Beltá se ha convertido en poco tiempo en un referente en el ámbito del interiorismo y la decoración tanto a nivel nacional como internacional.

Creamos objetos singulares, únicos. Objetos pensados para crear tendencias y para cumplir con las funciones para las que son diseñados. Beltá diseña productos y les confiere alma y espíritu. En su apuesta por el diseño, la compañía trabaja con diseñadores de reconocido prestigio internacional.

*Nuestro sistema de producción cuenta con las más avanzadas tecnologías de fabricación que unimos a nuestra tradición artesana para obtener una calidad óptima en nuestros modelos. Por todo ello, estamos **certificados por la normativa de Calidad ISO 9001.***

Beltá está comprometida con un crecimiento sostenible y respetuoso con el medio ambiente. Hacemos una fuerte inversión en investigación para obtener materiales, procesos mas eficientes y eficaces. Además parte de nuestros recursos se destinan a proyectos con fines sociales. Gracias a la calidad de nuestros productos, a su excelente diseño, la red comercial y logística de la empresa; Beltá está presente en mas de 30 países con un crecimiento constante año tras año fruto del esfuerzo de trabajar con las últimas tecnologías en distribución y venta de producto.

BELTÁ Mode de Vie

Née de la volonté de miser fermement sur le design et l'innovation, Belta est devenu en peu de temps une référence dans le domaine du design d'intérieur et décoration, tant nationale qu'internationale. Nous créons des objets singuliers, uniques. Objets conçus pour créer des tendances et de accomplir avec les fonctions pour lesquelles ils sont conçus. Beltá conçoit des produits et leur donne une âme et un esprit. Dans leur offre pour la conception, l'entreprise travaille avec des designers de renom international.

Notre système de production comprend les technologies de production les plus avancées, que nous rejoignons à notre tradition artisanale pour obtenir une qualité optimale dans nos modèles. Par conséquent, nous sommes certifiés par la norme exigeant de qualité ISO 9001.

Beltá est **engagée dans un développement durable** et écologique avec l'environnement. Nous faisons un fort investissement dans la recherche pour les matériaux, les processus plus efficient et efficaces. En plus, partie de nos ressources sont destinés aux projets à vocation sociale. Grâce à la qualité de nos produits, à son excellent design, au réseau commercial et logistique de la société, Beltá est présent dans plus de 30 pays avec une croissance soutenue année après année, grâce aussi à l'effort de travailler avec les technologies les plus récentes sur la distribution et la vente du produit.

Index

Sofa



Arko 52 - 53



Asso 30 - 33



Camp 28 - 29



Dion 50 - 51



Gaus 10 - 13



Goia 18 - 21



Huop 38 - 41



Loux 42 - 45



Newy 14 - 17



Ovvo 22 - 25



Slim 34 - 37



Suit 26 - 27



Time 46 - 49



Wing 4 - 9



Mood 56 - 57

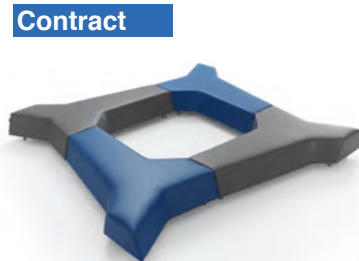

Edge 64 - 65



Kino 60 - 63



Link 68 - 69



Live M1 66 - 67



Live M2 66



Look 58 - 59



Hide 92



Inside 91



Nomi 93

Armchair



Arko 86



Boss 78



Delp 87



Diba 81



Emma 84



Even 77



Gica 89



Goia 79



Look 76



Marc 85



Muse 72 - 74



Opof 88



Pao 74 - 75



Play 82 - 83



Soho 80



Toupie 90

Table



Agol 97



Back 104



Deva 96



Even 99



Fres 107



Isen 102



Luna 98



Open 105



Pent 94 - 95



Pok 106



Raiz 100 - 101



Rund 103

Complement



Soft 109



Dodu - Cushions 108

FINISHES	110
FABRICS	111
TECHNICAL	118
PROJECTS	138
SHOWROOM	142
WEB-ENVIROMENT	144
AWARDS-QUALITY	145



WING sofa, canapé. EVEN table, mesa. FRES side table, mesita.



WING Dario Gagliardini

It is not a sofa but a seating system. Its identity is its capacity for transformation with its exchangeable elements to provide the sofa with new shapes terms of aesthetic or space.

It is an upholstery system which allows great flexibility starting from the bench as the basic element, which adding elements as arms and backrest we create the configuration to achieve a custom made element. You can also select the suggested compositions. A system suitable to answer to any demand. Can be totally opened or closed as a nest, full of charming pillows.

No es un sofá, sino un sistema de asientos en los que su identidad es la capacidad de transformarse debido a los elementos intercambiables para dar nuevas caras al sofá en términos sea de estética o sea de espacio.

Un sistema de tapizados que permite una gran flexibilidad a partir de la bancada, como elemento básico, y añadiendo elementos, tales como los brazos y los respaldos, para formar configuraciones que cumplen con los requisitos de poder personalizar o eligiendo en las composiciones sugeridas. Un sistema capaz de responder a las múltiples demandas: completamente abierto o completamente cerrado como un nido lleno de cojines acogedores.

Il n'est pas un canapé, mais un système de sièges où leur identité est la capacité de se transformer en raison des éléments interchangeables pour donner de nouveaux visages au canapé en termes d'esthétique ou d'espace.

Un système de tapissés qui permet une grande flexibilité à partir de l'assise, comme l'élément de base et en ajoutant les éléments, tels que les bras et retour, pour faire configurations qui satisfont les exigences pour pouvoir personnaliser ou choisir entre les compositions proposées. Un système capable de répondre à plusieurs demandes : totalement ouverte ou complètement fermée comme un nid plein de coussins confortables.



WING sofa, canapé. LUNA table, mesa. FRES side table, mesita. Salone del Mobile, Milano 2014.



GAUS sofa, canapé. SOHO armchair, butaca, fauteuil. AGOL table, mesa.

Its simple and tough construction together with natural and basic lines turn Gaus in a contemporary product.

Large cushions and good balance between comfort and firmness invites to rest. Structure and cushions with removable upholstery look for functionality.

Its design with symmetry between backrest and arm together with a wide program of elements offers the possibility of creating multiple combinations. Arms not removable, integrated in sofa's frame.

La construcción sencilla y robusta, junto a sus líneas naturales y básicas, convierten a Gaus en un producto con carácter atemporal.

Su gran amplitud de almohadas y un buen equilibrio entre firmeza y comodidad, invitan al descanso.

Con estructura y almohadas totalmente desfundables en búsqueda de una total funcionalidad.

Además, su diseño con simetría entre brazo y respaldo, junto a un amplio programa de elementos, ofrecen la posibilidad de crear multitud de combinaciones. Brazos no desmontables integrados en la estructura del sofá.

La construction simple et robuste, avec ses lignes naturelles et bases, font de Gaus un produit avec caractère intemporel.

Sa large gamme de coussins et un bon équilibre entre fermeté et confort, vous invitent au repos.

Avec la structure et des appuis-tête entièrement déhoussables en recherche d'une fonctionnalité totale.

En plus, son design avec une symétrie entre les bras et le dos, ainsi qu'une large gamme d'éléments, offrent la possibilité de créer de nombreuses combinaisons. Il n'est pas impossible d'enlever les accoudoirs, ils sont intégrés dans la structure du canapé.





NEWY sofa, canapé. DEVA tables, mesas. BACK side table, mesita.

NEWY

Sergio Muñoz

A contemporary look that can be adapted to all environments as open public areas, home or contract.

Newy has been designed to suit nowadays needs, considering design details and upholstery manufacturing. Its large seating area and dimensions have been developed thinking in comfort and considering aesthetic. Its shape is an asymmetric line that provides an innovative character, modern and elegant.

Presenta un aspecto contemporáneo pensando en todo tipo de espacios ya sea en el hogar o entornos públicos, contract.

Newy ha sido diseñado para adaptarse a las necesidades de nuestros tiempos teniendo en cuenta todos los detalles del producto y la fabricación de muebles tapizados. Su amplia sentada y sus dimensiones han sido desarrolladas pensando siempre en el confort sin dejar de lado la estética. La forma define una línea asimétrica que le proporciona un carácter innovador, moderno y elegante.

Il présente un aspect contemporain conçu pour s'adapter à toutes sortes de domaines, soit dans des environnements ouverts et publics, soit dans le ménage et le contract.

Newy a été conçu pour s'adapter aux besoins de notre époque, en tenant compte de tous les détails de la conception et la fabrication de meubles tapissés. Sa grande assise et ses dimensions ont été développées toujours pour trouver le confort sans oublier l'esthétique. La forme définit une ligne asymétrique qui offre un caractère innovant, modern et élégant.





GOIA sofa, canapé. GOIA armchair and pouff, butaca y pouff, fauteuil et pouff. OPEN side table, mesita. ISEN side table, mesita.

GOIA Pablo Cano

Goia armchair is the new Beltá proposal for those seeking comfort and originality. The idea of a product with a high component of craftsmans-hip coupled with forms that are wrapped to create an object whose beauty does not belong to any style or era. The curved line and the organic form in the interior are opposite to the accuracy and straightness of the exterior; the exquisite detail of the fold is stressed with the buttons. A model that serves both for avant-garde spaces and more classic; unique and versatile.

Goia es la nueva propuesta de Beltá para aquellos que buscan originalidad y comodidad. La idea de un producto con una alta componente de artesanía unida a las formas que se envuelven a sí mismas crean un objeto cuya belleza no pertenece a ningún estilo ni época. La línea curva y la forma orgánica en el interior se contraponen a la precisión y rectitud del exterior; el detalle exquisito del pliegue se remarca con los botones. Un modelo que sirve tanto para espacios vanguardistas como para los más clásicos; versátil e única.

Goia est la nouvelle proposition de Beltá pour ceux qui recherchent originalité et confort. L'idée d'un produit avec un haut composant d'artisanat combiné avec des formes qui s'enveloppent à eux-mêmes, à fin de créer un objet dont la beauté n'appartient pas ni à un style ni à une époque concrète. La ligne courbe et sa forme organique à l'intérieur contraste avec la précision et la rectitude à l'extérieur; le détail du pli est souligné avec les boutons. Un modèle qui est à l'avant-garde des espaces et aussi pour les plus classiques; versatile et unique.



OWO sofa, canapé. LUNA table, mesa. VITA side table, mesita.

Its special design makes it light and makes it a flexible product that transforms the spaces located in places full of dynamism and functionality in that.

This model is a risky exercise in search of organic and compact forms. Ovvo awakens the imagination of its creators and users who enjoy it.

Important: To choose fabric, consult us.

Su especial diseño lo convierte en un producto ágil que transforma a los espacios en que se encuentra en lugares llenos de dinamismo y funcionalidad.

Este modelo supone un arriesgado ejercicio de búsqueda de formas orgánicas y compactas. Ovvo despierta la imaginación de sus creadores y de los usuarios que lo disfrutan.

Importante: Para elegir tejido, consulte con fábrica.

Son spécial design lui donne une touche de dynamisme ce produit peut transformer les espaces en des lieux pleins de dynamisme et de fonctionnalité.

Ce modèle suppose un risqué exercice dans la recherche des formes organiques et compactes. Ovvo réveille l'imagination de ses créateurs et des utilisateurs.

Important: Pour choisir tissu, consulter avec l'usine.



SUIT

Robert Ortega

A model that offers a wide variety of modules to get so many compositions as customer need. Suit however is not a regular modular sofa. Suit is a clear example of our know-how, our taste for the careful manufacture and is a reflection of how our craftsmen are able to achieve personality to the simplicity. This model is open to the user using the game, inviting you to combine textures and colours in order to give shape to the space through its modules.

Un modelo que ofrece una amplia variedad de módulos para conseguir tantas composiciones como necesite el cliente. Suit sin embargo no es un sofá modular al uso; suit es un claro ejemplo de nuestro saber hacer, de nuestro gusto por la confección esmerada y es un reflejo de como nuestros artesanos son capaces de dar personalidad a la sencillez. Este modelo se abre al usuario mediante el juego, invitándolo a combinar texturas y colores para dar forma al espacio a través de sus módulos.

Un modèle qui propose une grande variété de modules pour obtenir tant des compositions comme le client ait besoin. Cependant, Suit n'est pas un canapé modulable à utiliser; Suit est un clair exemple de notre savoir-faire, notre goût pour la fabrication minutieuse et il est le reflet de comment nos artisans sont capables de donner personnalité à la simplicité. Ce modèle est ouvert à l'utilisateur à travers du jeu, lui invitant à combiner les textures et les couleurs pour donner corps à l'espace à travers de ses modules.



CAMP

Arbel

A different sofa, complex in its idea but with a perfect result.

A classical soul translated into a contemporary language through the resource of the line and the organic shape. A stimulating exercise of exploring the formal avant-garde. In its execution is its soul and its comfort is its original language.

Un sofá distinto, complejo en cuanto a su concepto de partida pero con un resultado impecable.

Un alma clásica traducida a un lenguaje contemporáneo a través del recurso de la línea y la forma orgánica. Un estimulante ejercicio de exploración de la vanguardia formal. En su ejecución reside su alma, y la comodidad es su lenguaje original.

Un canapé différent et complexe sur son concept de départ, mais avec un résultat impeccable.

Une âme classique traduits dans un langage contemporaine à travers du ressource de la ligne et la forme organique. Un exercice stimulant dans l'exploration de l'avant-garde formel. Dans son exécution est son âme, et le confort est leur langage d'origine.



ASSO

Dario Gagliardini

Asso looks for the essence of the objects to turn into a powerful expression sign. Through the refining shapes we get and object of perfect shapes in which we have the arm movement to explore different positions. Its cushions grant the users and outstanding comfort. Arm with hinge easy to remove.

Asso busca la esencia de los objetos para convertirse en un poderoso signo de expresión. A través de la depuración de la forma se obtiene un modelo de líneas exactas en las que aparece el movimiento del brazo para explorar diferentes posiciones. Además sus características almohadas proporcionan al usuario un confort espectacular. Brazo con bisagra fácil de desmontar.

Asso cherche l'essence des objets pour se transformer en un signe puissant d'expression. À travers de l'épuration des formes on obtient un modèle avec des lignes exactes dans lesquelles le mouvement du bras apparaît pour explorer différentes positions. De plus ses caractéristiques oreillers fournissent à l'utilisateur un confort spectaculaire.



SLIM

Arbel

A light and elegant sofa; and however it is not ruled by the geometry but by art. The detail becomes the best way to convert a casual in a timeless object. Slim rises from the ground on a wooden stand, natural; allowing integrated silent in environments of great purity. A model with a wide modular variety that has been created as a practical-aesthetic solution for users who know the importance of a good design.

Un sofá ligero, horizontal, elegante; y sin embargo no está regido por la geometría sino por el arte. El detalle se convierte en la mejor forma de convertir un objeto casual en un objeto atemporal. Slim se eleva del suelo apoyado en un soporte de madera, natural; permitiendo que se integre silencioso en ambientes de gran pureza. Un modelo con una gran variedad modular que ha sido concebido como una solución práctico-estética para los usuarios conocedores de la importancia de un buen diseño.

Un canapé léger, horizontal, élégant et cependant il n'est pas régi par la géométrie, mais par l'art. Le détail devient la meilleure façon de faire d'un objet occasionnel un objet intemporel. Slim s'élève du sol reposant sur un support en bois naturel; permettant l'intégration silencieuse dans des atmosphères avec une grande pureté. Un modèle avec une gamme modulaire qui a été conçue comme une solution pratique-esthétique pour les utilisateurs familiarisés avec l'importance de la bonne conception.



SLIM sofa, canapé. OPOF poufs. RUND tables, mesas.



SLIM sofa, canapé. RUND tables, mesas.

HUOP

Arbel

Sofa that studies geometry as an expression guide, playing it and using it to obtain an exactly proportion that moves between horizontal design and visual lightness. The reclining headrest allows enjoying the comfort of this model without refusing its aesthetic when the headrests are folded. Its wide modularity allows many compositions for our home. Sofa or module bigger than 200 cm are with removable arms.

Sofá que estudia la geometría como vehículo de expresión, la interpreta y la utiliza para obtener unas proporciones exactas que se mueven entre la horizontalidad del diseño y su ligereza visual. El cabezal abatible permite disfrutar de la comodidad de este modelo sin renunciar a la estética que posee cuando los cabezales están plegados. Su amplia variedad modular, permite además, todo tipo de composiciones para el hogar. Sofá o módulo mayor de 200 cm esta preparado para desmontar los brazos en destino.

Canapé qui initie la géométrie comme moyen d'expression, l'interprète et l'utilise pour obtenir des proportions exactes qui se décalent entre l'horizontalité des formes et sa légèreté visuelle. L'oreiller abattible permet donner de la commodité à ce modèle sans renoncer à l'esthétique qui lui donne les oreillers pliés. Son ample variété modulaire, permet toute espèce de compositions pour le foyer. Canapé ou modules plus grands que 200 cm sont préparés pour démonter les bras à destination.





HUOP sofa, canapé. MARC armchair, butaca, fauteuil. OPOF pouf. TRAC table, mesa.

LOUX Arbel

Details of edge sewing allow colour combination to emphasize its shape.

Sofa whose main characteristic is its great comfort. Cared detailed design, giving the piece a rhythm and a movement never seen, perfect to fit and dress miscellaneous spaces. The seat cushion with a wide thickness and the baseboard emphasize the highline style of the piece. Its wide modularity allows many compositions for our home.

Los detalles en las costuras que se embellecen con un vivo a través de las aristas del modelo permiten combinar colores y resaltar su forma. Sofá cuya principal característica es su gran comodidad. Diseño cuidado en los detalles, de este modo otorgan a la pieza un ritmo y un movimiento sin igual perfecto para vestir los espacios más dispares. La almohada asiento de gran espesor y el zócalo enfatizan el marcado estilo de la pieza. Su amplia variedad modular, permite además, todo tipo de composiciones para el hogar.

Les détails dans les coutures, qui donnent beauté avec un passepoil, permettent la combinaison des couleurs et remarquer sa forme. Canapé dont la caractéristique principale est sa grande commodité. Un Design soigné dans tous ses détails, en ajoutant à la pièce un rythme et un mouvement sans égal, parfait pour habiller les espaces les plus divers. Le coussin d'assise à une grande épaisseur et le socle soulignent le style marqué de la pièce. Son ample variété modulaire, permet toute espèce de compositions pour le foyer.





LOUX sofa, canapé. RAÍZ table, mesa.

TIME

Arbel

The accuracy of the geometric structure harmonizes with the strong arms square, solid. Designed to be configured at any time for a better use. This linearity allows you to play with the nice contrast of soft support pads. Removable cover option. It includes a decoration cushion (45x45cm) for each arm.

El rigor de la estructura geométrica se armoniza con la de los contundentes brazos cuadrados, sólidos. Diseñado para ser configurado en cualquier momento para su mejor uso. Esta linealidad permite jugar con el agradable contraste de los cojines blandos del respaldo.

Opción desenfundable. Incluye un cojín de decoración (45x45cm) por cada brazo.

La rigueur de la structure géométrique s'harmonise avec les solides accoudoirs carrés. Dessiné pour être configuré à tout moment pour sa meilleure utilisation. Cette forme linéale permet de jouer avec la contraste agréable des coussins mous du dossier. Option déhoussable. Comprend un coussin de décoration (45x45cm) pour chaque bras.





TIME sofa, canapé. EVEN armchair, butaca, fauteuil. AGOL table, mesa. BACK side table, mesita. RUND side tables, mesitas.

DION

Jorge Pensi

Dion is a program of sofas based on modules allowing versatile adjustments for every space. Aesthetically it prevails the contrast between a "box" of minimal dimensions and large cushions: therefore it is possible to enjoy a comfortable and great seat for small spaces.

Dion es un programa de sofás a base de módulos que permiten adaptaciones versátiles a cada espacio. En la estética predomina un contraste entre una "caja" de dimensiones mínimas y cojines generosos: de esta manera, se puede disfrutar de un asiento cómodo y ancho, incluso en espacios pequeños.

Dion est un programme de canapés à base de modules qui permettent plusieurs adaptations pour chaque espace. Esthétiquement parlant le contraste prédomine entre une "caisse" de dimensions minimales et des coussins volumineux : de cette façon, on peut jouir d'un confortable et large siège, même dans des petits espaces.





ARKO

Dario Gagliardini

The combination between modernity and tradition turn Arko into the ideal product to decorate sophisticated style interiors. Its modern shapes remind traditional pieces of contemporary taste. The sofa or module is prepared to take apart the base from the backrest.

La combinación entre modernidad y tradición hacen de Arko el producto ideal para decorar los interiores que aman comunicar un espíritu sofisticado. La modernidad de sus líneas hacen revivir piezas tradicionales con gusto contemporáneo. Sofá o módulo está preparado para que pueda ser desmontado en destino, separando base de respaldo.

La combinaison entre modernité et tradition font d'Arko le produit idéal pour décorer les intérieurs qui aiment communiquer un esprit sophistiqué. La modernité de ses lignes font revivre des pièces traditionnelles avec un goût contemporain. Canapé ou module préparé pour pouvoir être démonté chez le destinataire en séparant la base du dossier.



MOOD Arbel

Italian type, very comfortable opening, the mechanism opening system collects the pillows without having to remove them. The backup saves pillows inside. Sofa with wide modular range, allowing all kinds of compositions for the home. Different arms shapes to choose. Sofa bed of pure lines with a studied design resulting in a practical, functional and beautiful object.

Sistema de apertura tipo italiana, de apertura muy cómoda, el mecanismo recoge las almohadas sin necesidad de quitarlas. El respaldo guarda las almohadas en su interior. Sofá de amplia variedad modular, permitiendo todo tipo de composiciones para el hogar. Posibilidad de elegir entre diferentes tipos de brazos. Sofá cama de líneas puras con un diseño estudiado que da como resultado un objeto práctico, funcional y bello.

Système d'ouverture italienne très simple. Le mécanisme recueille les oreillers sans avoir besoin de les supprimer. Le dossier garde les oreillers à l'intérieur. Canapé avec ample gamme modulaire permettant toutes sortes de compositions pour la maison. La possibilité de choisir entre différents types de bras. Canapé convertible de lignes simples, avec un design étudié, ce qui donne un objet pratique, fonctionnel et beau.

OP.1



OP.2



OP.3



OP.4



OP.5



OP.6



LOOK Gallega Design

Look model combines to perfection comfort, sobriety and pure lines as well as wood and steel combined in order to integrate it in the environment we desire to achieve.

In that collection you find sofas and armchairs in different measures to be adapted to any demanding area.

El modelo Look conjuga a la perfección la comodidad, la sobriedad y la pureza de líneas, así como la combinación con materiales como el acero o la madera a fin de facilitar la perfecta integración en el ambiente que se desea conseguir.

La colección, compuesta de sofás y sillones en variedad de medidas permite adaptarse a los espacios más exigentes.

Le modèle Look allie à la perfection le confort, la simplicité et la pureté des lignes, ainsi que la combinaison avec des matériaux comme l'acier ou le bois afin de faciliter l'intégration parfait dans l'environnement que vous souhaitez obtenir.

La collection, composée de canapés et de fauteuils dans une variété de mesures permet de s'adapter aux espaces plus exigeants.



LOOK sofa, canapé. LOOK armchair, butaca, fauteuil. AGOL table, mesa. PENT tables, mesas.





KINO Eduardo Climent

An ideal piece for contract environments, waiting areas and lobbies. A sofa with dynamic shapes and strong personality and recognized immediately. A combination between classical and avant-garde design of great simple shapes.

Es un modelo idóneo para entornos contract, salas de espera y vestíbulos. Un sofá de líneas dinámicas, de fuerte personalidad y al instante reconocible. Una combinación de diseño clásico y vanguardia de gran simplicidad formal.

Un modèle adapté pour les environnements contrat, salles d'attente et halls. Un canapé des lignes dynamique, de forte personnalité et instantanément reconnaissable. Une combinaison de conception classique et avant-garde d'une grande simplicité formelle.



KINO sofa, canapé. LUNA table, mesa. VITA side table, mesita.

EDGE

Jacob Pringiers

Edge is a game proposal, a proposal where the geometry and complementarity creates a simple object in appearance but that hides a detailed shape research. The main feature that offers Edge is its ability to create complex shapes from a single module. Designed especially for Contract spaces is ideal for composing images and sensations.

Edge es una propuesta de juego, una propuesta en donde la geometría y la complementariedad crean un objeto en apariencia sencillo pero que esconde un estudio detallado de la forma. El rasgo principal que ofrece Edge es su capacidad de crear formas complejas a partir de un único módulo. Pensado especialmente para espacios contract es idóneo para componer imágenes y sensaciones.

Edge nous offre une liberté de jeu, un jeu où la géométrie et la complémentarité ont créé un objet d'une apparence simple mais qui cache une étude très détaillée de la forme. Le trait principal qu'Edge offre est sa capacité de créer des formes complexes à partir d'un module unique. Pensé spécialement pour des espaces contract, il est idéal pour composer des images et des sensations.



LIVE

Dsignio

Organic and friendly design, its wide modularity and variety of parts make it a perfect versatile piece to current environments. Live intended for decoration of public places such as hotels, nightclubs, shops, so it grants the function of seating and decorative lighting of the premises, using strips of flexible LEDs, with RGB, under the upholstery. Product is completed with a circuit designed specifically for these LEDs light intensity control. The bench is detachable and assembly is done using lateral anchorage.

Diseño orgánico y amigable, su amplia modularidad y variedad de piezas lo convierten en una pieza versátil perfecta para ambientes actuales. Live destinado a la decoración de sitios públicos como hoteles, salas de fiesta, tiendas, de manera que cumpla la función de mobiliario de asiento e iluminación decorativa del recinto, por medio de la integración de tiras de LEDs, flexibles con cambio de color RGB, bajo el tapizado. El banco es desmontable, el montaje se realiza mediante anclaje lateral.

Un design organique et amiable, son ample modularité et variété dans ses pièces le font une pièce versatile, parfaite pour les climats actuels. Live destiné à la décoration des espaces publics comme les hôtels, pubs, magasins, de façon à ce qu'il accomplisse la fonction de mobilier de siège et d'illumination décorative de l'endroit par l'intégration de bandes de LEDs, des fils électriques avec changement de couleur RGB, sous la tapisserie. Le banc est démontable, le montage est réalisé au moyen d'un ancrage latéral.



LIVE M2



LIVE M1

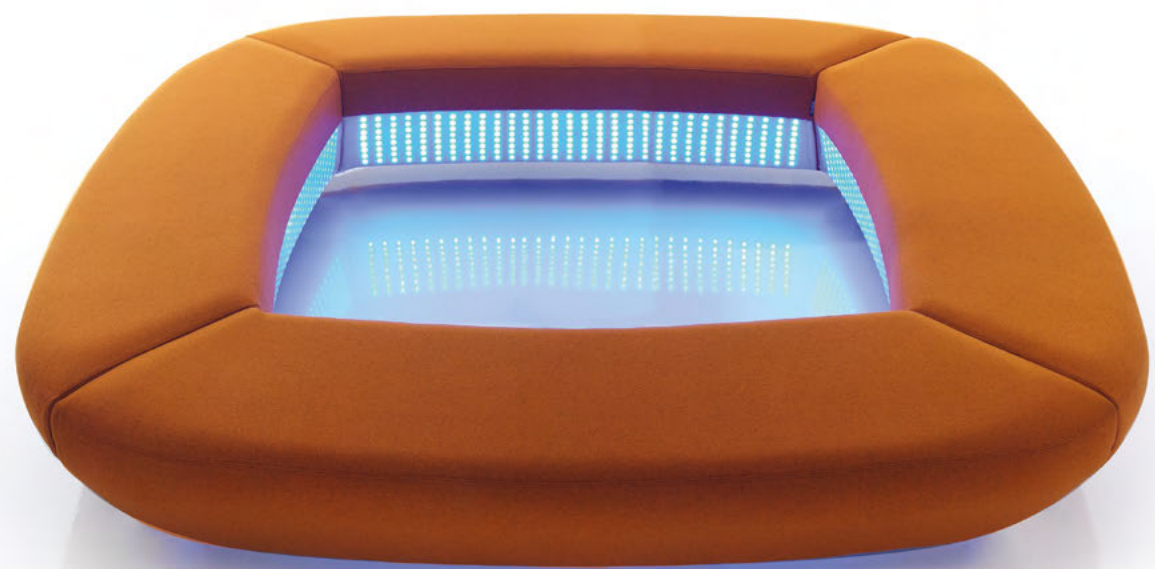

LIVE M2 sofa, canapé. LIVE M1 bench, banco, banc.



LINK Dsignio

Modular sofa with several combinations with a simple and sophisticated design. Model of large size and extreme comfort thanks to the polyurethane foam mix. Simple shapes that hide a complex frame.
Sofa or module bigger than 200cm is ready to disassemble the arms in destiny.

Sofá modular de múltiples combinaciones con un diseño de gran sencillez y sofisticación. Modelo de generosas dimensiones y extrema comodidad gracias a la combinación de espumas de poliuretano utilizadas. Formas de una aparente simplicidad tras la que se esconde una compleja estructura.
Sofá o módulo mayor de 200cm está preparado para que los brazos puedan ser desmontados en destino.

Canapé modulaire à plusieurs options avec design de grande simplicité et sophistication. Modèle de dimensions généreuses et de confort extrême grâce à la combinaison des mousses de polyuréthane utilisées. Des formes d'une apparente simplicité derrière lesquelles se cache une structure complexe et une recherche méticuleuse.
Canapé et module de plus de 200 cm préparé pour que les bras puissent être démontés à destination.





ARMCHAIRS butacas, fauteuils. Tables, mesas. SIDE TABLES, mesitas. BELTÁ.

MUSE

Arbel

Muse is an ideal auxiliary armchair for the contract sector or home living spaces where you look for a model simple and fun at the same time but designed from a moderate point of view.

It is very important the choice of the fabrics in this product, so that through good choice we can get a single object. Agile details specify its structure: the curve of the backrest, the slim support, buttons... frame it in environments in which it is used.

Muse es una colección de mobiliario auxiliar, compuesta de silla, butaca y 2 plazas, ideal para el sector contract o para espacios en el hogar en donde se busque un modelo sencillo y divertido a la vez pero diseñado desde un prisma moderado.

Cobran gran importancia la elección de los tejidos en este producto, ya que a través del buen gusto podemos obtener un objeto único. Los detalles ágiles especifican su estructura: la curva del respaldo, el delgado apoyo, los botones; y la enmarcan en los ambientes en los que se utiliza.

Muse est une collection de mobilière auxiliaire, composée de chaise, fauteuil et deux places, idéal pour le secteur de contrat ou pour espaces dans la maison où il faut un modèle facile et amusant en même temps, mais conçu d'un point de vue modéré. Le choix des tissus devient très important dans ce produit, car nous pouvons obtenir un objet unique avec notre bon goût. Les détails agiles spécifient sa structure : la courbe du dossier, le support mince, les boutons; et ils les encadrent dans les environnements dans lesquels elle est utilisée.



MUSE armchair, butaca, fauteuil. MUSE chair, silla, chaise. RUND table, mesa.



Provides an excellent combination of comfort, lightness and reduced sizes but at same time offers a generous and pleasant seating depth.

Pao's goal is the perfect combination of shape, functionality, comfort, detail and aesthetic. It is such a versatile chair that can fit in any place, public or private not compromising quality and perfection.

An elegant, timeless and functional object. Simple and beautiful, inspired by the international life style of its designer, Lluís Codina.

Proporcionan una excelente combinación de comodidad, ligereza y proporciones reducidas, al tiempo que ofrece un generoso y agradable profundidad de asiento.

Pao tiene como objetivo la combinación exacta de forma, función, comodidad, detalle y estética. Es una butaca tan versátil que puede resultar adecuada para cualquier lugar, público o privado, sin comprometer la calidad y la perfección.

Un objeto elegante, atemporal y funcional, de gran simplicidad y belleza, inspirado por el estilo de vida internacional de su diseñador Lluís Codina.

Il donne une excellente combinaison de confort, de légèreté et de proportions réduits, au même temps qui offre une profondeur d'assise sympathique et généreuse.

PAO a comme but la combinaison exacte de la forme, la fonction, le confort, le détail et l'esthétique. C'est un fauteuil si polyvalent qu'il peut être situé à n'importe quel endroit, public ou privé, sans compromettre la qualité et la perfection.

Un objet élégant, intemporel et fonctionnel, d'une grande simplicité et beauté, inspirée par le style de vie international de son concepteur Lluís Codina.

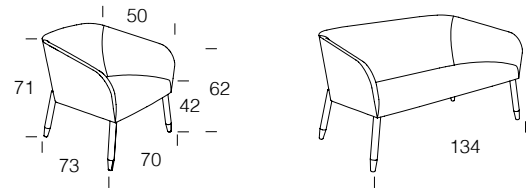

PAO armchair, butaca, fauteuil. EMMA chair, silla, chaise. BACK table, mesa.



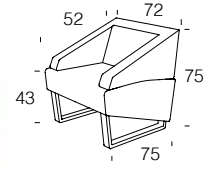

LOOK Gallega Design

In that collection you find sofas and armchairs in different measures to be adapted to any demanding area. Look model combines to perfection comfort, sobriety and pure lines as well as wood and steel combined in order to integrate it in the environment we desire to achieve.

La colección, compuesta de sofás y sillones en variedad de medidas permite adaptarse a los espacios más exigentes. El modelo Look conjuga a la perfección la comodidad, la sobriedad y la pureza de líneas, así como la combinación con materiales como el acero o la madera a fin de facilitar la perfecta integración en el ambiente que se desee conseguir.

La collection, composée de canapés et de fauteuils dans une variété de mesures permet de s'adapter aux espaces plus exigeants. Le modèle Look allie à la perfection le confort, la simplicité et la pureté des lignes, ainsi que la combinaison avec des matériaux comme l'acier ou le bois afin de faciliter l'intégration parfait dans l'environnement que vous souhaitez obtenir.

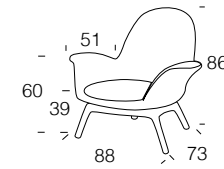

EVEN Robert Ortega

Even armchair is a piece of apparent simplicity, however acquires a special character thanks to the curves that wrap it and give its shape. The baseboard is of solid wood that acquires movement due to the circulation of the legs. A Beltá bet for natural execution of their models. However, Even becomes the alternative for those seeking clarity in the design with a conservative point of view.

La butaca Even es una pieza de aparente sencillez que sin embargo adquiere un carácter especial gracias a las curvas la envuelven y le dan forma. La base es un zócalo de madera que adquiere movimiento debido a la tirada de las patas, una apuesta de Beltá por la naturalidad en la ejecución de sus modelos. Con todo, Even se convierte en la alternativa para aquellos que buscan lucidez en el diseño con un punto de vista conservador.

Le fauteuil Even est une pièce de la simplicité apparente qui cependant a acquis un caractère spécial, grâce à des courbes qui lui enveloppent et lui donnent forme. La base est un support de bois qui acquiert mouvement en raison de la circulation des pieds, un pari de Beltá par la naturalité dans l'exécution de leurs modèles. Cependant, Even devient l'alternative pour ceux qui recherchent la lucidité dans la conception avec un point de vue conservateur.



BOSS

Pablo Cano

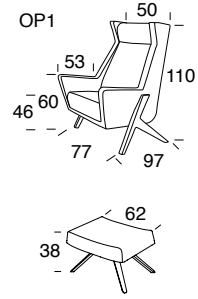

Vintage style armchair. Design based on the stylistic principles that marked a tendency and which today are back and trendy. The subtlety of its forms, planes causing it and the delicacy of its balance make it a unique and iconic piece. Props go out of the conventional and help to represent the idea of returning and interpretation of classical shapes.

Butaca de estilo vintage basa su diseño en los principios estilísticos que marcaron tendencia y que hoy vuelven a estar en boga. La sutileza de sus formas, los planos que la originan y la delicadeza del equilibrio que presenta la hacen una pieza singular e icónica. Los apoyos pasan de lo convencional y ayudan a representar la idea de vuelta e interpretación de formas clásicas.

Fauteuil style vintage basée sur les principes stylistiques qui ont marqué une tendance et qui recommencent à être très demandé de nos jours. La subtilité de ses formes, les plans qui l'animent et la délicatesse de l'équilibre qu'elle présente la rendent une pièce singulière et iconique. Les appuis passent du conventionnel et aident à représenter l'idée du retour avec l'interprétation de

GOIA

Pablo Cano

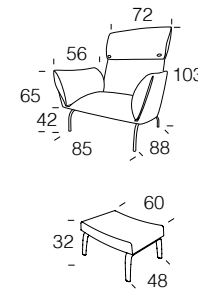

The idea of an armchair with a high component of craftsmanship combined with shapes that are wrapped to themselves create an object whose beauty does not belong to any style or era. The curved line and the organic form in the interior contrasts with the accuracy and straightness of the exterior; the exquisite detail of the fold is stressed with the buttons. A model that is for avant-garde spaces and for the classics; versatile and unique.

La idea de una butaca con una alta componente de artesanía unida a las formas que se envuelven a sí mismas crean un objeto cuya belleza no pertenece a ningún estilo ni época. La línea curva y la forma orgánica en el interior se contraponen a la precisión y rectitud del exterior; el detalle exquisito del pliegue se remarca con los botones. Un modelo que sirve tanto para espacios vanguardistas como para los más clásicos; versátil e única.

L'idée d'un fauteuil avec un haut composant d'artisanat combiné avec des formes qui s'enveloppent à eux-mêmes à fin de créer un objet dont la beauté n'appartient pas ni à un style ni à une époque concret. La ligne courbe et sa forme organique à l'intérieur contraste avec la précision et la rectitude à l'extérieur; le détail du pli est souligné avec les boutons. Un modèle qui est à l'avant-garde des espaces et aussi pour les plus classiques; versatile et unique.



SOHO Robert Ortega

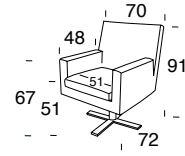

An agile armchair with lightweight appearance and serene gesture that embraces us, inviting us to relax. Careful ergonomics and elegant presence are some of the elements that distinguish this product. Soho predisposes us to share the space and mix with others. It suggests a new typology, extremely flexible in use, suitable for home and for public spaces.

Una butaca ágil, de aspecto ligero y gesto sereno que nos abraza, nos invita a relajarnos, de cuidada ergonomía y elegante presencia son algunos de los elementos que distinguen a este producto. Soho nos predispone a compartir el espacio y facilita la forma de relacionarse con los demás, sugiere una nueva tipología, extremadamente flexible en su uso, apta tanto para hogar como para espacios públicos.

Un fauteuil agile, de caractère légère et geste calme qui nous embrasse, nous invite à nous reposer. Très ergonomique et présence élégante sont quelques-uns des éléments qui distinguent ce produit. Soho nous prédispose à partager l'espace et faciliter la façon d'avoir relation avec les autres. Suggère une nouvelle typologie, extrêmement flexible dans son utilisation, adaptée aussi bien pour la maison et pour les bâtiments publics.

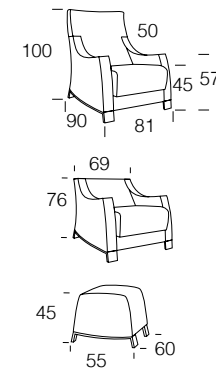

DIBA Dario Gagliardini

Diba, main characteristic is due to the availability of two versions of backrest: high and low. Model of sinuous lines that invites you to relax. Its daring, but content design is able to integrate in any type of space thanks to its simplicity and its two options available. In addition the customer can choose between legs of solid beech wood or polished stainless steel.

Diba, la principal característica se debe a las disponibilidad de dos versiones de respaldo: alto y bajo. Modelo de líneas sinuosas que invita al descanso. Su atrevido, pero contenido diseño es capaz de integrarse en cualquier tipo de espacio gracias a su sencillez y a sus dos opciones disponibles. Además el cliente puede elegir entre patas de madera maciza de haya o pie en acero inoxidable pulido.

Diba, sa caractéristique principale est due à sa disponibilité de deux versions de dossier: haut et bas. Le modèle de lignes sinueuses invitent au repos. Son audacieux design est capable d'être intégré dans n'importe quel type d'espace grâce à sa simplicité et la disponibilité des deux options. De plus le client peut choisir entre des pieds en bois massif de hêtre ou pieds en acier inoxydable.



PLAY

Jorge Pensi

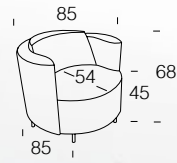

Playful design, but reserved: circular individual armchair, which joins other armchairs, ottomans and tables, that dissolves in sets never seen. Its morphology involves the decorator and the user forcing them to participate in a game of forms, supporting their creativity and awakening curiosity. Its wide variety of finishes, combined with the unique of this piece; allow us to create absolutely unique ambiances hard to imitate.

Su diseño es lúdico, pero contenido: Parte de una planta circular en la butaca individual, que se une con otras butacas, poufs y mesitas, que se disuelve en conjuntos nunca vistos. Su morfología implica al decorador y al usuario. Les obliga a participar en un juego de formas, apoyando su creatividad y despertando la curiosidad. Su amplia variedad de acabados, unido a lo singular de esta pieza; nos permiten crear ambientes absolutamente únicos difíciles de imitar.

Son design est ludique mais contenu : il part d'un plan circulaire dans le fauteuil individuel et qui rejoint les autres fauteuils, poufs, petites tables et qui se dissout dans des compositions jamais vues. Sa morphologie implique le décorateur et l'utilisateur. Elle les oblige à participer dans un jeu de formes, en soutenant sa créativité et en réveillant la curiosité. Son ample variété d'achevés, qui font complément à la singularité de cette pièce nous permet de créer des climats absolument uniques et difficiles d'imiter.



EMMA

Jaime Bouzaglo

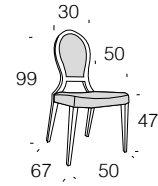

Modern, young, smooth, sensual, photogenic and attractive piece. Suitable for all environments thanks to the double aspect of his design: classical but with contemporary lines. It is an ergonomic and functional piece. Armchair With a wide range in terms of final appearance: trimmed, lacquered or natural wood; In addition to the possibility of upholstered backrest or leave it hollow. A model that can be used both at home and at contract spaces.

Pieza moderna, joven, fluida, sensual, fotogénica y atractiva. Adaptable a todos los entornos gracias a la doble vertiente de su diseño: clásico pero con líneas contemporáneas. Se trata de un objeto ergonómico y funcional. Con una amplia posibilidad en cuanto a su aspecto final: tapizados, lacados o madera al natural; además de la posibilidad de tapizar el respaldo o dejarlo hueco. Un modelo que puede utilizarse tanto en espacios contract como en hogar.

Une pièce moderne, jeune, sensuelle, photogénique et attractive. Adaptable à tous les environnements grâce au double versant de son design : classique mais avec des lignes contemporaines. Il s'agit d'une pièce ergonomique et fonctionnelle. Avec une ample possibilité en ce qui concerne son apparence finale : tapissée, laquée ou un bois naturel; en plus la possibilité de tapisser le dossier ou de le laisser creux. Modèle qui peut être utilisé dans des espaces contract comme dans un foyer.



MARC

Jorge Pensi

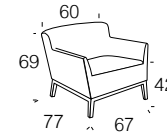

Marc is synonymous with elegance, an example of rationality that turns it into a contemporary object. Its formal clarity makes it to be combinable with any type of furniture and its clean presence as well as originality turn this piece perfect for both home and contract.

Marc es sinónimo de elegancia, un ejemplo de racionalidad que la convierte en un objeto contemporáneo. Su claridad formal le hace ser combinable con cualquier tipo de mobiliario y su presencia limpia y original lo hacen perfecto tanto para hogar como para contract.

Marc est le synonyme de l'élégance, un exemple de rationalité qui le transforme en objet contemporain. Sa simplicité formelle lui donne la caractéristique d'être combinable avec n'importe quel type de mobilier et son originale présence le font parfait tant pour foyer comme pour contract.



ARKO

Dario Gagliardini

Its modern shapes remind traditional pieces of contemporary taste. The combination between modernity and tradition turn Arko into the ideal product to decorate sophisticated style interiors.

La modernidad de sus líneas hacen revivir piezas tradicionales con gusto contemporáneo. La combinación entre modernidad y tradición hacen de Arko el producto ideal para decorar los interiores que aman comunicar un espíritu sofisticado.

La modernité de ses lignes font revivre des pièces traditionnelles avec un goût contemporain. La combinaison entre modernité et tradition font d'Arko le produit idéal pour décorer les intérieurs qui aiment communiquer un esprit sophistiqué.

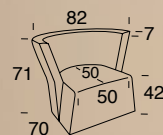

DELP

Dario Gagliardini

With a true taste of mid-20th century. DELP armchair is among all creativity. Its ambiguous shapes, sometimes organic others geometric, are a challenge to the user. The special arm shape gives a special comfort and style in which the play of planes and edges allow us to enjoy this armchair as a compact joint. Another of its main characteristics is the shape of the front that is specially designed to increase comfort. Possibility of using swivel base or legs.

Con un cierto sabor de mediados del siglo XX. el sillón Delp es ante todo creatividad. Sus formas ambiguas, a veces orgánicas, a veces geométricas, son todo un reto para el usuario. La tirada especial de su brazo le da una especial comodidad y un estilo en el que el juego de planos y aristas nos permiten disfrutar de la butaca como un conjunto compacto. Otra de sus principales características es la forma del frente que esta especialmente diseñada para aumentar su comodidad. Posibilidad de utilizar pie giratorio o cuatro patas.

Avec certain goût du moitié du XX.e siècle le fauteuil Delp est avant tout créativité. Ses formes ambiguës, parfois organiques, parfois géométriques, sont tout un défi pour l'utilisateur. Le effet spécial de son bras lui donne une commodité spéciale et un style dans lequel le jeu de plans et d'arêtes nous permettent de jouir du fauteuil comme ensemble compact. Autre de ses caractéristiques principales est la forme du front qui est spécialement créé pour augmenter son confort. Possibilité d'utiliser une base pivotante ou quatre pieds.

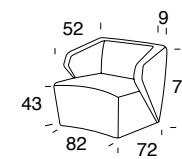

OPOF Dario Gagliardini

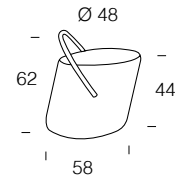

In that collection you find sofas and armchairs in different measures to be adapted to any demanding area. Look model combines to perfection comfort, sobriety and pure lines as well as wood and steel combined in order to integrate it in the environment we desire to achieve.

La colección, compuesta de sofás y sillones en variedad de medidas permite adaptarse a los espacios más exigentes. El modelo Look conjuga a la perfección la comodidad, la sobriedad y la pureza de líneas, así como la combinación con materiales como el acero o la madera a fin de facilitar la perfecta integración en el ambiente que se desea conseguir.

La collection, composée de canapés et de fauteuils dans une variété de mesures permet de s'adapter aux espaces plus exigeants. Le modèle Look allie à la perfection le confort, la simplicité et la pureté des lignes, ainsi que la combinaison avec des matériaux comme l'acier ou le bois afin de faciliter l'intégration parfait dans l'environnement que vous souhaitez obtenir.

GICA Eduardo Climent

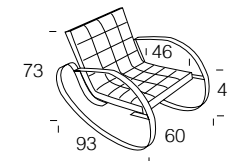

It is an ergonomic and functional piece, with curved lines, of great simplicity and attractive design. Its apparent lightness holds a solid structure but with movement when the user uses it. Gica, rocking chair has simple and elegant shapes. Perfection in their finishes make it a piece of difficult execution but whose end result is surprising for its purity and versatility. Gica earned several honors and awards of the Spanish furniture industry.

Se trata de una pieza ergonómica y funcional, con un diseño de líneas curvas, de gran simplicidad y atractivo. Su aparente ligereza encierra una estructura sólida pero con movimiento cuando el usuario la utiliza. Gica, mecedora de formas sencillas y elegantes. La perfección en sus acabados la convierten en una pieza de difícil ejecución pero cuyo resultado final sorprende por su pureza y versatilidad. Gica ha obtenido varios reconocimientos y premios del sector del mueble español.

Il s'agit d'une pièce ergonomique et fonctionnelle, son design avec des lignes courbes, avec une grande simplicité et attractif. Son apparente légèreté enferme une structure solide avec mouvement. Berceuse dont les formes sont simples et élégantes. La perfection dans son exécution la convertie en pièce de difficile exécution mais dont le résultat final surprend par sa pureté et versatilité. Gica a obtenue des nombreux insignes reconnus dans le secteur du meuble Espagnole



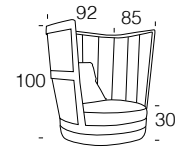

TOUPIE Nieves Contreras

A micro architecture in the living room, a cozy space in which to isolate to relax, listen to music, read... A low and wide stool on which comes to position itself with a high backrest made of metal. Swivel base in order to be able to orientate towards one end of the room, or into the wall or a close window, and to isolate ourselves and create an own space.
 .First prize, competition of furniture design.

Una microarquitectura en el salón, un espacio acogedor en el que poder aislarse para descansar, escuchar música, leer... Un pouf bajo y ancho, sobre el que viene a posicionarse un respaldo alto realizado en metal. La base es giratoria, de forma a poder orientarse hacia un lado del salón, o hacia la pared o una ventana cercana, y así poder aislarse y crear un espacio propio.
 .Primer Premio, Concurso de Diseño del Mueble.

Microarchitecture dans le salon, un espace accueillant dans lequel vous pouvez vous isolez et vous reposez, écouter de la musique, lire... Pouf bas et large, sur lequel se positionne un haut dossier en métal. La base est pivotante, d'une manière qui s'oriente vers un côté du salon, ou vers le mur ou vers une fenêtre pour pouvoir s'isoler et créer son propre espace.
 .Premier Prix, Concours de Conception du Meuble.



INSIDE Rafa y Miguel Ángel García

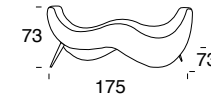

Dynamic and avant-garde shapes distinguish the INSIDE divan. Piece with remarked shapes and studied ergonomics, expresses a strong personality that does not leave indifferent.
 Product awarded and recognized by the furniture industry.

Formas dinámicas y vanguardistas distinguen a la chaise-longue INSIDE. Pieza de líneas marcadas de estudiada ergonomía, expresa una fuerte personalidad que no deja indiferente.
 Producto galardonado y reconocido por el sector del mueble.

Des formes dynamiques et d'avant-garde distinguent la chaise longue INSIDE. Pièce de lignes marquées et d'ergonomie soignée, elle exprime une forte personnalité qui ne laisse pas indifférent.
 Produit lauréat et reconnu par le secteur du meuble.



HIDE Leitmotiv

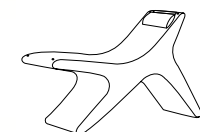
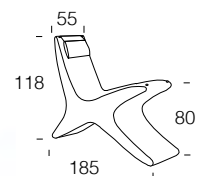

Hide is an amazing product aimed at an audience that seeks its own style and personality in furniture. We offer two different resting positions: one to lie and one to be more incorporated, but keeping both the comfort demanded for a relax furniture. Metal leg on both sides.
Product awarded and recognized by the furniture industry.

Hide es un producto sorprendente destinado a un público que busca estilo propio y personalidad en sus muebles. Ofrecemos dos posiciones de descanso diferenciadas: una para tumbarse y la otra para estar más incorporado, pero manteniendo en ambas la comodidad que exigen los muebles de relax. Patas de metal a ambos lados.
Producto galardonado y reconocido por el sector del mueble.

Hide est un produit surprenant qui s'adresse à un public cherchant un style propre et personnel dans ses meubles. Nous offrons deux positions de repos différentes : une pour s'allonger et l'autre pour être plus incorporé tout en conservant le confort qu'exigent les meubles relax. Pieds de métal aux deux côtés.
Produit lauréat et reconnu par le secteur du meuble.



NOMI Eduardo Climent

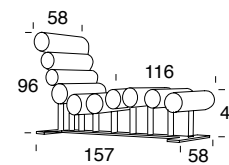

The project consists of a divan of steel structure, made in stainless steel and upholstered with removable cylinders attached to it. In its use, by using materials in the lumbar and back areas which allow to Flex backwards, as per pressure exerted and the recovery once the user stop using it, which allows the product to be adapted to any user, regardless of their weight and height.
.First prize, competition of furniture design.

El proyecto consiste en un diván de estructura metálica, realizado en acero inoxidable y cilindros tapizados desfundables unidos a la misma. En su uso, al utilizarse materiales en la zona lumbar y respaldo que permiten la flexión hacia atrás, según sea la presión ejercida y su recuperación una vez el usuario deje de utilizarla, se consigue una adaptación del producto para cualquier persona, independientemente de su peso y altura.
.Primer Premio, Concurso de Diseño del Mueble.

Le projet consiste en un divan de structure métallique, effectué en acier inoxydable et cylindres tapisés unis cette dernière. Dans son utilisation, en étant utilisé des matériels dans la zone lombaire et du soutien qui permettent la flexion en arrière, selon est la pression exercée et sa récupération une fois que l'utilisateur cessera de l'utiliser, on obtient une adaptation du produit pour toute personne, indépendamment de son poids et hauteur.
.Premier Prix, Concours de Conception du Meuble.



PENT Dsignio

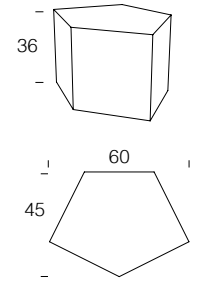

Pent is a modular system of pentagonal pieces that can be repeated many times to create countless compositions. It is a puzzle which to play with to create the better form to your needs. Possibilities are countless and could also be used as a bench. Finishing is in natural Ash wood which provides warmth and timeless.

Pent es un sistema modular formado por una pieza pentagonal que puede repetirse creando innumerables composiciones. Es un puzzle con el que jugar a crear la forma que más se adapte a tus necesidades. Las posibilidades son infinitas, incluso puede emplearse como banco. El acabado de las piezas en fresno natural proporciona calidez y atemporalidad.

Pent est un système modulaire composé d'une pièce pentagonale qui peut se répéter, pour créer des multiples compositions. Il est comme un puzzle avec lequel vous pouvez jouer pour créer la forme qui convient le mieux à vos besoins. Les possibilités sont infinies, même elle peut être utilisée comme une banque. La finition des pièces en frêne naturel fournit la chaleur et l'intemporalité.

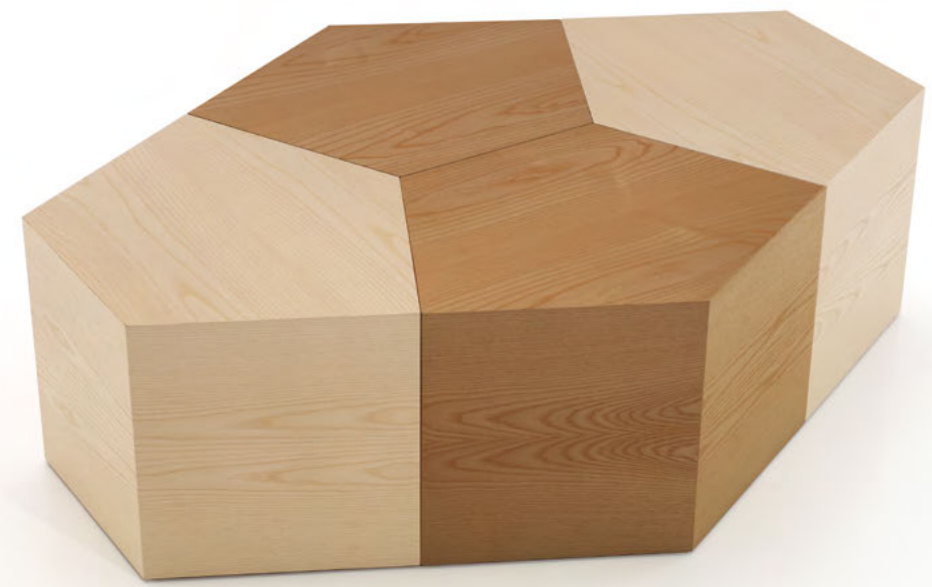
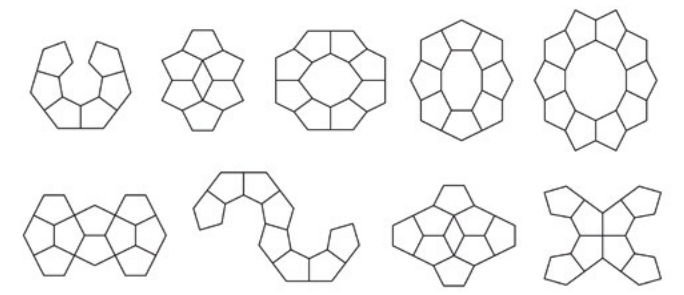

DEVA Pablo Cano

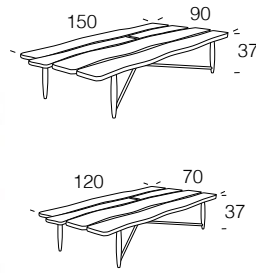

Deva combines the appearance almost archaic in raw wood together with new techniques in the treatment of this material. As a result, a sensational structure shown naked to the user which reflects warmth and elegance. The power of the wood expressed as an object whose aesthetic transcends by its timelessness.

Deva aúna el aspecto cuasi arcaico de la madera en bruto con las nuevas técnicas en el tratamiento de este material. El resultado; una sensacional estructura que se presenta desnuda al usuario de la que mana calidez y elegancia. Todo el potencial de la madera expresado como un objeto cuya estética trasciende por su atemporalidad.

Deva combine l'aspect quasi archaïque du bois à l'état brut avec nouvelles techniques dans le traitement de ce matière. Le résultat est une structure étonnante qui se présente nue à l'utilisateur avec chaleur et élégance. Tout le potentiel du bois exprimé sous un objet dont l'esthétique transcende par son intemporalité.



AGOL Dario Gagliardini

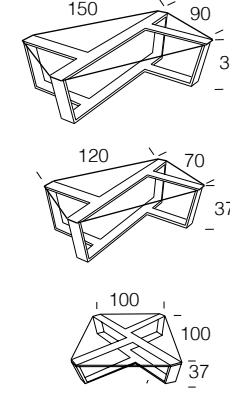

The precision treating raw materials make it a singular element. The sections of its structural elements are generous and contrast with strength with the apparent lightness of that design. An artistic expression source that designer show us thorough geometry. Solid oak wood frame with possibility of different finishes. 1cm tempered security glass.

La precisión en el tratamiento de materiales naturales la hacen un elemento único. Las secciones de sus elementos estructurales son generosas y contrastan con solidez la aparente ligereza de este diseño. Una fuente de expresión artística que el diseñador nos muestra a través de la geometría. Estructura de madera maciza de roble con posibilidad de obtener diferentes acabados. Cristal templado de 1cm de espesor.

La précision dans le traitement des matériels font d'elle un élément unique. Les sections de ses éléments structurels sont généreuses et résistent à l'apparente légèreté de son design. Source d'expression artistique que le dessinateur nous montre à travers de la géométrie. Structure en chêne massif de Hêtre avec possibilité d'obtenir différents finitions. Cristal tempérant de 1cm d'épaisseur.



LUNA

Paolo Mauri

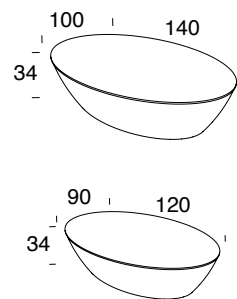

Luna is born with the idea of representing the simplicity of its natural shape. Its natural clean shapes invites us to think in something timeless and away from any conformity. Something essential as the moon.

Top in marble or solid blockboard wood of oak. Base is turned MDF block. Lacquered finished in different colors (see table of finishes).

Luna nace de la idea de representar la sencillez en su forma mas natural, sus formas puras y limpias nos invitan a pensar en algo atemporal y fuera de cualquier conformismo. Algo esencial, como la Luna.

Sobre de mesa en mármol o tablero de madera maciza alistonada de roble. Base, volumen fresado sobre bloque MDF. Acabado lacado en diferentes colores (ver tabla de acabados).

Luna est née pour représenter la simplicité dans sa forme la plus naturelle. Ses formes pures et propres nous invitent à penser à quelque chose hors du temps et hors de toute complaisance.

Quelque chose d'essentiel, comme la lune. Panneau de table en marbre ou en bois massif abouté de chêne. Base, volume fraisage sur bloc MDF. Finition laquée en différentes couleurs (voir tableau des finitions).



EVEN

Arbel

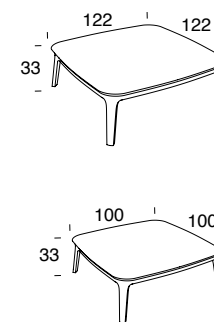

This product reveals a work with an extraordinary expressive strength. As decorative furniture is a key element in any contemporary and timeless environment.

Frame in solid ash wood and counter top made in marble or solid blockboard wood are the elements of these product. Available in different sizes.

Este producto revela un trabajo de extraordinaria fuerza expresiva, como mobiliario decorativo representa un elemento clave en cualquier ambiente contemporáneo de carácter atemporal.

Una estructura de madera maciza de fresno y un sobre realizado en mármol o en madera maciza alistonada son los elementos que componen este producto. Disponible en diferentes formatos.

Ce produit révèle un travail d'une force expressive extraordinaire. Comme les meubles décoratifs, il représente un élément clé de toute atmosphère contemporaine de caractère intemporel.

Une structure de bois massif de frêne et un panneau supérieur en marbre ou en bois massif abouté sont les éléments qui composent ce produit. Disponible en différents formats.



RAÍZ

Lluís Codina

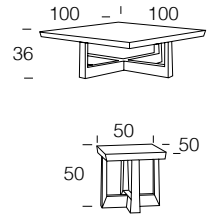

The volume is the main feature of this table which has been designed to extract the full artistic potential of the beauty of the wood. The subtle games of the streaks and the delicate transitions between elements are remarkable on a set with spectacular strength both physically and visually. Available in different sizes and with glass top. Solid walnut wood.

El volumen es la principal característica de esta mesa ideada para extraer de la belleza de la madera todo su potencial artístico. Los sutiles juegos de las vetas y las delicadas transiciones entre las piezas que la forman destacan sobre un conjunto de una solidez espectacular tanto física como visualmente. Disponible en diferentes tamaños y con sobre de cristal. Estructura de madera maciza de nogal.

Le volume est la principale caractéristique de cette table, qui est imaginée pour extraire toute la beauté du bois et tout son potentiel artistique. Les jeux subtils de ses veines et les délicates transitions entre les pièces qui la forment se font remarquer sur l'ensemble d'une solidité spectaculaire tant physique que visuellement. Disponible dans différentes tailles et avec couvercle de cristal. Structure en bois massif de noyer.



ISEN Arbel

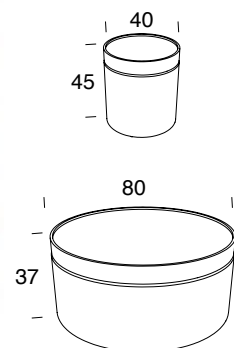

The character of this table is their materials and simple design. On the top we have the pure vision of artisans work in solid wood that grants a unique and individual character to each table. Base is upholstered giving warmth and as a result is the ideal complement to any of our products, either a sofa or an armchair.

Mesa que se caracteriza por la fuerza de sus materiales y la simplicidad de su diseño. En el sobre destaca la pureza visual que se consigue a partir del trabajo artesanal con la madera maciza, que le confiere un carácter único e individual a cada una de las mesas. La base de este modelo está tapizada aportando calidez y resultando ideal como complemento a cualquiera de nuestros productos, sofás o butacas.

Table qui se caractérise par la solidité de ses matériaux et la simplicité de sa conception. Le panneau supérieur met l'accent sur la pureté visuelle que s'obtient à partir du travail artisanal avec le bois massif. C'est ce travail qui lui confère un caractère unique et individuel à chaque table. La base de ce modèle est tapissée, en offrant de la chaleur et en donnant un complément idéal à n'importe quel de nos produits, de canapés et de fauteuils.



RUND Dsignio

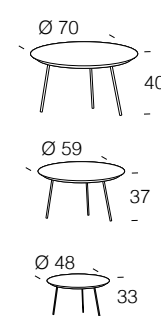

Rund is a family of three side tables that can be used independently or in a group, creating different compositions thanks to their sizes and heights. We looked for the maximum formal simplicity to eliminate the superfluous and focus on a few lines that provide a great visual delicacy. Solid oak wood. Finished can be in natural wood colour or lacquered in different colours..

Rund es una familia de tres mesas auxiliares que se pueden emplear de forma independiente o en grupo, creando diferentes composiciones gracias a sus tamaños y alturas. Hemos buscado la máxima simplicidad formal para eliminar todo lo superfluo y centrarnos en unas líneas que les otorgan una gran delicadeza visual. Estructura de madera maciza de roble. Las podemos encontrar con acabado en madera natural o lacadas en distintos colores.

Rund est une famille de trois tables basses que vous pouvez installer de façon indépendante ou groupée, avec de nombreuses possibilités de compositions grâce à leurs différentes tailles. Nous avons cherché la simplicité des lignes, ce qui leur confère une grande délicatesse visuelle. Structure en bois massif de chêne. Vous pouvez choisir une finition en bois naturel ou laquée de différents couleurs.



BACK Robert Ortega

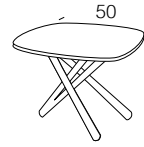
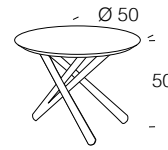

Simplicity is not incompatible with the expressiveness and Beltá evidenced it once again creating this table where the geometry and visual game built a great precision object.

Solid oak wood frame. Finished can be in natural wood colour or lacquered in different colours.

La sencillez no está reñida con la expresividad y Beltá lo demuestra una vez más creando esta mesa en donde la geometría y el juego visual construyen un objeto de gran precisión.

Estructura de madera maciza de roble. Las podemos encontrar con acabado en madera natural o lacadas en distintos colores.

La simplicité n'est pas incompatible avec l'expressivité et Belta fait la preuve encore une fois en décidant de créer cette table où la géométrie et le jeu visuel construisent un objet d'une grande précision.

Structure en bois massif de chêne. Possibilité de finitions en naturel, wengue, noyer, merisier, blanc.



OPEN Arbel

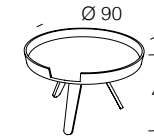
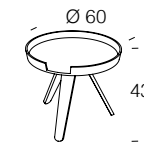

Open is a playful and practical Furniture piece that can be placed in any place, even if it is one piece or a group of them. Is described as a real domestic tool.

Solid oak wood legs. Top in solid blockboard wood or lacquered fiber. Option to choose color. See table of finishes.

Open es una pieza de mobiliario lúdica y práctica que se puede instalar en cualquier lugar, ya sea individualmente o en grupo, se describe como un utensilio doméstico real.

Patas en madera de roble macizo. Sobre de mesa en tablero alistonado de madera o fibra lacada. Posibilidad de diferentes colores, ver tabla de acabados.

Open est une amusante pièce de mobilier et pratique qui peut s'installer n'importe où, soit individuellement soit en groupe. Il est décrit comme un ustensile intérieur réel. Les pieds donnent l'impression de légèreté et de dynamisme.

Pieds en chêne massif. Panneau de table avec tableau de bois ou de fibre laqué. Possibilité de différentes couleurs, voir le tableau des finitions.



POK Arbel

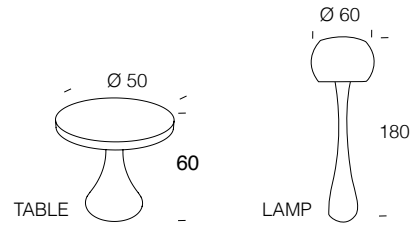

Side table and floor lamp with turned base with organic shapes inspired in nature that grants a particular and elegant appearance. A winding and attractive contour that creates a proposal with strong personality. Solid beech wood turned base. Top in solid blockboard wood or lacquered fiber. Option to choose color. See table of finishes.

Mesa auxiliar y lámpara de base torneada, con formas orgánicas inspiradas en la naturaleza que le confieren un aspecto más particular y elegante. Un perfil sinuoso y atractivo que crea una propuesta de fuerte personalidad. Base torneada en madera maciza de haya. Sobre de mesa en tablero alistonado de madera maciza o fibra lacada. Posibilidad de diferentes colores, ver tabla de acabados.

Table auxiliaire et lampadaire avec base en tour, avec des formes organiques inspirées par la nature qui lui donnent un aspect plus particulier et plus élégant. Un profil sinueux et attractif qui crée une proposition avec une forte personnalité. Base tourné en bois massif en hêtre. Panneau de table latté en bois massif ou fibre laqué. Possibilité de différentes couleurs, voir le tableau des finitions.



FRES Arbel

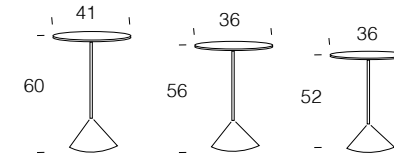

The small Fres side table has a fine design, created with a playful and movement sense giving as a result an extremely useful and flexible element. Fres is easy to move and has the right size for a book or cup of coffee. Is a table to use in active environments. Solid wood of sycamore. Wood base with iron soul inside.

La pequeña mesa auxiliar Fres es un diseño muy sutil, creado con un sentido lúdico y de movimiento, dando como resultado un elemento extremadamente útil, flexible. Fres se mueve con facilidad a lo largo de una habitación, ocupa un lugar perfecto para un libro o una taza de café, una mesa que funciona en entornos basados en la actividad. Sobre y estructura de madera maciza de sicomoro. Base de madera con alma interior de hierro.

Le petit guéridon Fres est une conception très subtile, créée avec un sens ludique et du mouvement, ayant pour résultat un élément extrêmement utile et flexible. Fres se déplace facilement dans toute une chambre il occupe un endroit parfait pour un livre ou une tasse de café, une table qui fonctionne sur les environnements basés sur les activités. Panneau supérieur et structure en bois massif de sycomore. Base en bois avec une âme intérieur de fer.



DODU - CUSHION Arbel

Pillow's collection where the versatility and colourful combinations are the elements forming them. Its innovative design makes them extremely useful, offering the possibility to mix textures and colours as well as hiding them or showing them as needed through turns and formal changes. Interior cotton coat stuffing with down touch padding (Microgel).

Colección de cojines en donde la versatilidad y las combinaciones cromáticas son los elementos que les dan forma. Su novedoso diseño les hace ser altamente versátiles, ofrecen la posibilidad de mezclar texturas y colores y de ocultarlos o mostrarlos según se necesite mediante giros y cambios formales. Funda interior de algodón rellena de microfibras tacto plumón (Microgel).

Collection de coussins où la versatilité et les combinaisons chromatiques sont les éléments essentiels qui donnent plus de forme. Sa versatilité offre la possibilité de mêler les textures et les couleurs et de les cacher ou de les montrer selon le besoin par la double face. Housse intérieure en coton remplie de microfibras tacto duvet (Microgel).



Ref: 974DB
45x45 cm



Ref: 974ME
55x45 cm



Ref: 974BO
45x45 cm



Ref: 974ES
55x45 cm



Ref: 955CO
45x45 cm



Ref: 969CO
45x45 cm



Ref: 964CO
53x25 cm



Ref: 940RE
60x60 cm



Ref: 940CO
55x45 cm



Ref: 970CO
60x60 cm

SOFT Arbel

Ottoman collection which we play with comfort, colours, sizes and manufacturing details in order to obtain a family of products thought for urban environments without refusing warmth. A versatile product offering a great bunch of possibilities according customer's taste.

Colección de pouffs en los que se juega con la comodidad, los colores, las medidas y los detalles constructivos para crear una completa familia de productos ideados para los ambientes más urbanos sin renunciar a la calidez. Es un producto versátil que ofrece gran variedad de posibilidades dependiendo del gusto del cliente.

Collection de pouffs qui offre un certain jeu avec la commodité, les couleurs, les mesures et les détails constructifs pour créer une famille complète de produits imaginés pour les climats les plus urbains sans renoncer à la chaleur. C'est un produit versatile qui offre une grande variété de possibilités en dépendant du goût du client.



FINISHES / ACABADOS / FINITIONS

WOOD / MADERA / BOIS



WENGUE
OAK
ROBLE
CHÊNE

CHERRY
CEREZO
MERISIER

ASH
FRESNO
FRÊNE

WALNUT
NOGAL
NOYER

BEECH
HAYA
HÊTRE

SYCAMORE
SICOMORO
SYCOMORE

STEEL / ACERO / ACIER



STAINLESS STEEL
ACERO INOX
ACIER INOX

CHROMED
CROMADO
CHROMÉ

BLACK
NEGRO
NOIR

WHITE
BLANCO
BLANC

SILVER LEAF
PAN DE PLATA
ARGENT

GOLD LEAF
PAN DE ORO
OR

PAINTED / LACADO / PEINTURE



STONE
PIEDRA
PIERRE

GREY
GRIS

SEA
MAR
MER

GREEN
VERDE
VERT

FUCHSIA
FUCSIA

ORANGE
NARANJA



BLACK
NEGRO
NOIR

WHITE
BLANCO
BLANC

RED
ROJO
ROUGE

SHINE BLACK
NEGRO BRILLO
NOIR BRILLIANT

SHINE WHITE
BLANCO BRILLO
BLANC BRILLIANT

SHINE CHOCOLAT
CHOCOLATE BRILLANTE
CHOCOLAT BRILLIANT

CRYSTAL / CRISTAL / VERRE



TRANSPARENT
TRANSPARENTE

WHITE
BLANCO
BLANC

BLACK
NEGRO
NOIR

MARBLE / MARMOL / MARBRE



WHITE
BLANCO
BLANC

BROWN
MARRÓN IMPERIAL
BRUN

BLACK
NEGRO
NOIR

FABRICS / TEJIDOS / TISSUS

SUPPLIER PROVEEDOR FOURNISSEUR	COLLECTION COLECCIÓN	SERIE
LEATHER-PVC / PIELS-PVC / CUIR-PVC		
MARIANO FARRUGIA	SAVANA DALMATATA ANTIQ	PVC+PIEL STAR 4 PIEL CIERVO 8 SAVANA 8 DALMATATA 9 ANTIQ COLONIAL 9
ALONSO MERCADER		STAR 2 MAXIUM 3 RX 2 GRAIN 2 FLOR 2
SPRADLING CONTRACT-PROJECT		SILVERTEX 4 VALENCIA 3 DOLCE 5 VOGUE 4

FABRICS / TELAS / TISSUS

CREVIN		Divine - Zip - Ri ZIP, RITUAL TEXTURAS	DUO 2 DAS 2 MOSAIC 2 PLANA 2 SCOTH 2 YORK 2 ZIP 2 KRAC 2 VIBRANT 2 BRICKS 3 DROM 3 MIRAGE 3 DIVINE 3 PRISMA 3 TETRA 3 SUBLIM 3
RUSTIKA		RUSTIKA ALWAYS NOW TOMORROW	2
GÜELL-LA MADRID LE-CREATIONS		FACE 3 BRIAN 4 BRIAN 4 MAC 4 CLIN 4 TOD 4 REST 4	
SUNBRELLA		NATTÉ 4	

SUPPLIER PROVEEDOR FOURNISSEUR	COLLECTION COLECCIÓN	SERIE
FABRICS / TELAS / TISSUS		
DESIGNERS GUILD	BRERA 7 DELTONA 6 TRASIMENO 8 PINSTRIPE 5 PANARO 5 CHISTIAN LACROIX 8 CULSWICK 9	
L'INTERNO	MOVIE 5 BINGO 4 FUNNY 4 BEAT 5 BUBBLE 6	
VESCOM	CRES 4 LOMBOC 5 SAMAR 4 NADI 5 LANI 6 YUMA 6 NAURU 7	
kvadrat	PAUSE 3 6 BLITZ 2 7 FIELD 7 STEELCUT TRIO 8 HOT 7 REMIX 7 DIVINA 3 9 DIVINA MELANGE 2 9 SCUBA 7 CAVA3 8 TOPAS2 8	
Gabriel	CONSULT WITH US CONSULTAR CON FÁBRICA CONSULTER AVEC L'USINE	
camira	CONSULT WITH US CONSULTAR CON FÁBRICA CONSULTER AVEC L'USINE	
MISSONI	CONSULT WITH US CONSULTAR CON FÁBRICA CONSULTER AVEC L'USINE	
SILTEX exitsolutions	CONSULT WITH US CONSULTAR CON FÁBRICA CONSULTER AVEC L'USINE	
ROMO	CONSULT WITH US CONSULTAR CON FÁBRICA CONSULTER AVEC L'USINE	
CASAMANCE	CONSULT WITH US CONSULTAR CON FÁBRICA CONSULTER AVEC L'USINE	

FOR OTHER REFERENCES OF THOSE OR OTHER SUPPLIERS IN WICH YOU COULD BE INTERESTED CONSULT WITH US.
 PARA OTRAS REFERENCIAS DE ESTOS U OTROS PROVEEDORES EN LOS QUE ESTÉ INTERESADO CONSULTAR EN FÁBRICA.
 SI VOUS ÊTES INTÉRESSÉS POUR D'AUTRES RÉFÉRENCES DE SES FOURNISSEURS, CONSULTER AVEC L'USINE.



S - 3 6600 slate S - 3 6576 dolphin S - 3 6577 steel S - 3 6578 lightgrey S - 3 6579 ivory S - 3 6580 linen S - 3 6581 khaki S - 3 6582 liver S - 3 6583 cinnamon S - 3 6584 coffee S - 3 6585 espresso S - 3 6586 onyx

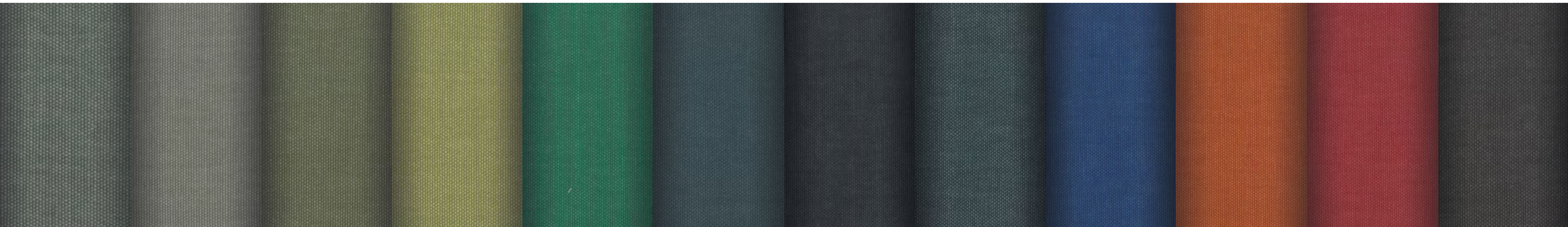

S - 3 6587 wood S - 3 6588 army S - 3 6589 olive S - 3 6590 pistacho S - 3 6591 turtle S - 3 6592 petrol S - 3 6593 navy S - 3 6594 denim S - 3 6595 sapphire S - 3 6596 mandarin S - 3 6597 coral S - 3 6598 nightshade

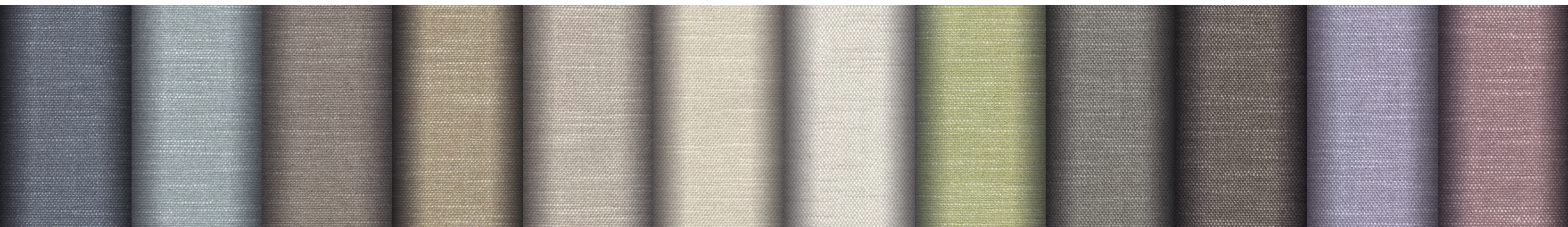

S - 3 6563 S - 3 6564 S - 3 6565 S - 3 6566 S - 3 6567 S - 3 6568 S - 3 6569 S - 3 6570 S - 3 6571 S - 3 6572 S - 3 6574 S - 3 6575

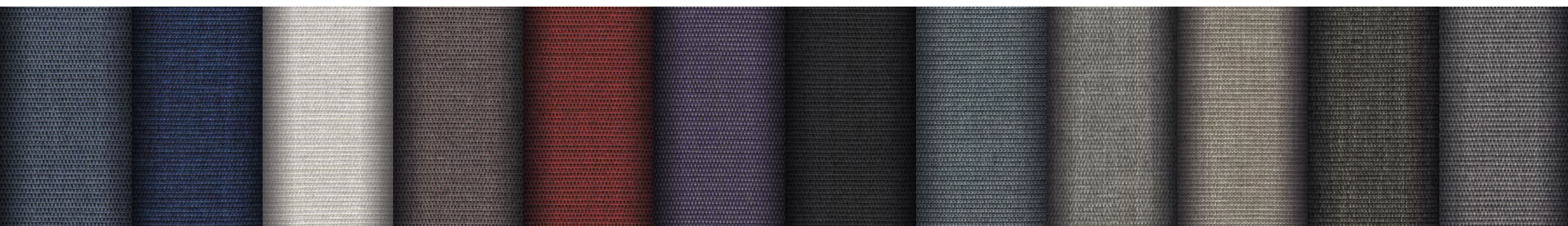

S - 3 5123 S - 3 5124 S - 3 5125 S - 3 5127 S - 3 5129 S - 3 5132 S - 3 5137 S - 3 5138 S - 3 6524 S - 3 6523 S - 3 65227 S - 3 6525

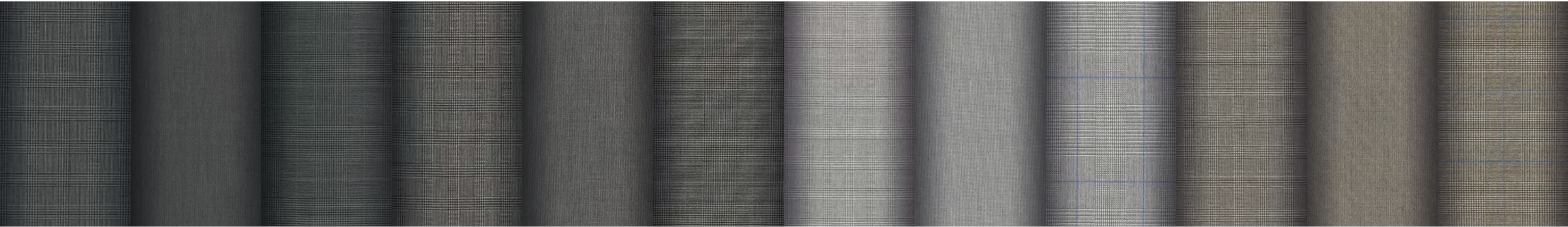

S - 2 6577 sapphire S - 2 6578 sapphire S - 2 6579 sapphire S - 2 6580 graphite S - 2 6581 graphite S - 2 6582 graphite S - 2 6583 pewter S - 2 6584 pewter S - 2 6585 pewter S - 2 6589 oak S - 2 6590 oak S - 2 6591 oak

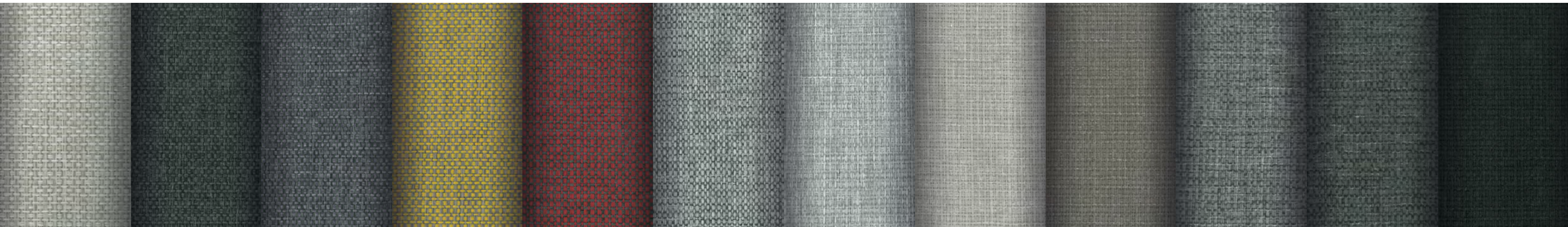

S - 1 2616 ecru S - 1 2620 charcoal S - 1 2621 lavender S - 1 2625 maize S - 1 2627 scarlet S - 1 2630 grey S - 1 2631 dolphin S - 1 2632 ivory S - 1 2633 desert S - 1 2634 sepia S - 1 2635 taupe S - 1 2637 onyx

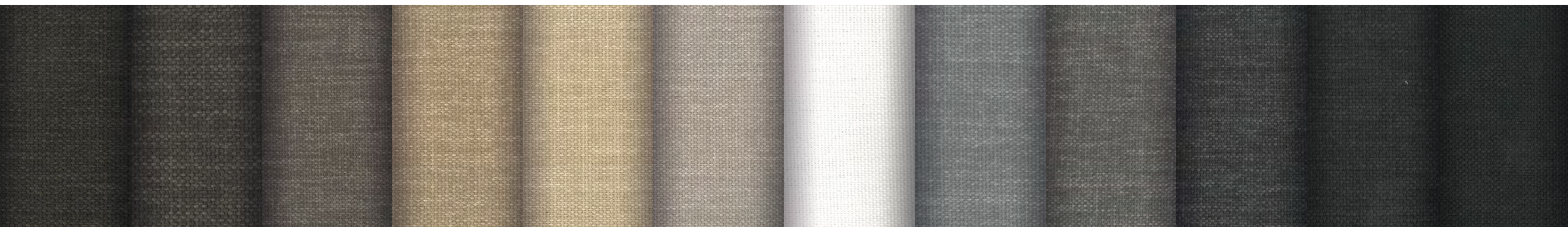

S - 1 2638 chocolate S - 1 2639 coffee S - 1 2640 brown S - 1 2641 sand S - 1 2642 beige S - 1 2643 kaki S - 1 2644 ivory S - 1 2645 grey S - 1 2646 liver S - 1 2648 antracite S - 1 2649 onyx S - 1 2650 black

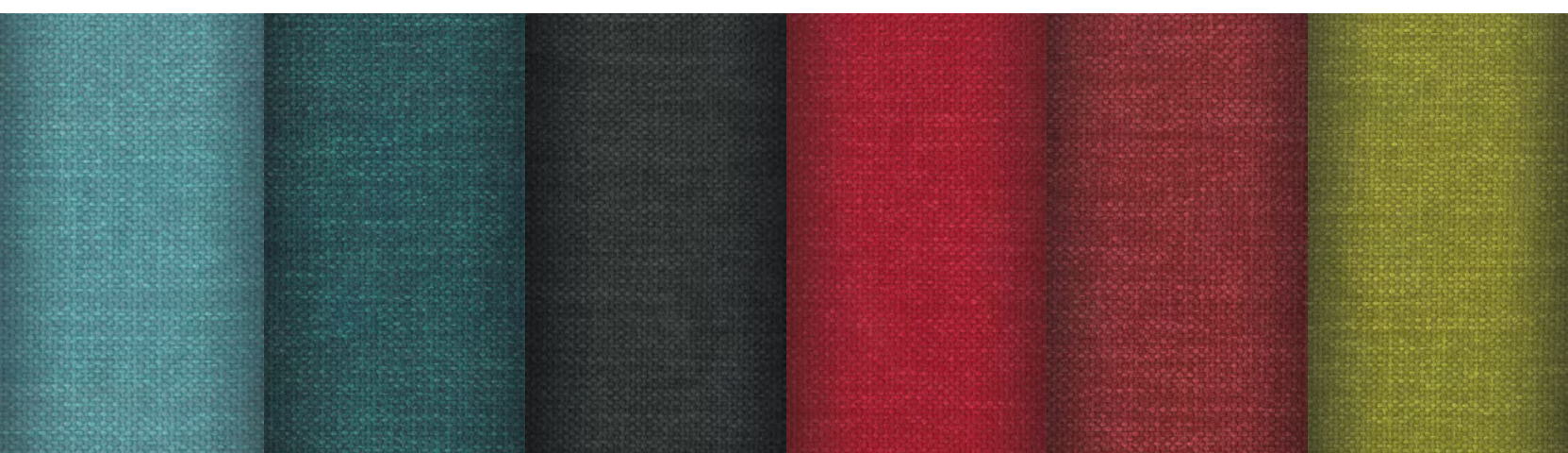

S - 1 2651 azure S - 1 2652 petrol S - 1 2653 navy S - 1 2655 fire S - 1 2656 red S - 1 2658 olive

References	Width	Composition	Martindale	Cleaning
S - 3 6576 a 6601	138 cm	100% CO	25000 cycles	
S - 3 6563 a 6575	140 cm	68% PES 32% CO	60000 cycles	
S - 3 5123 a 5138 6522 a 6529	140 cm	50% PP 31% PES 19% CO	36000 cycles	
S - 2 6577 a 6591	143 cm	63% PES 33% CV 4% EA	100000 cycles	
S - 1 2616 a 2637	138 cm	100%PP	22000 cycles	
S - 1 2638 a 2659	145 cm	100%PES	100000 cycles	

Los colores de los tejidos, polipiel y pieles pueden variar de una partida a otra. / The colors of the fabrics, synthetic leather and leather may differ from one consignment to the next. / Les couleurs des tissus, des cuirs synthétiques et des cuirs, ils peuvent varier d'une commande à une autre.

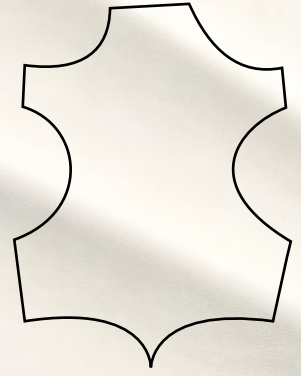

S - 9 9600 S - 9 9601 S - 9 9602 S - 9 9603 S - 9 9604 S - 9 9605 S - 9 9606 S - 9 9607 S - 9 9608 S - 9 9609 S - 9 9610

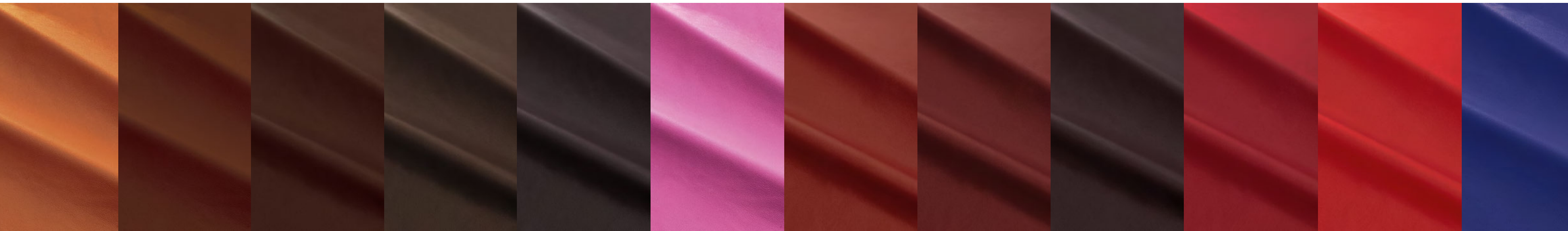

S - 9 9611 S - 9 9612 S - 9 9613 S - 9 9614 S - 9 9616 S - 9 9615 S - 9 9617 S - 9 9618 S - 9 9619 S - 9 9620 S - 9 9621 S - 9 9622

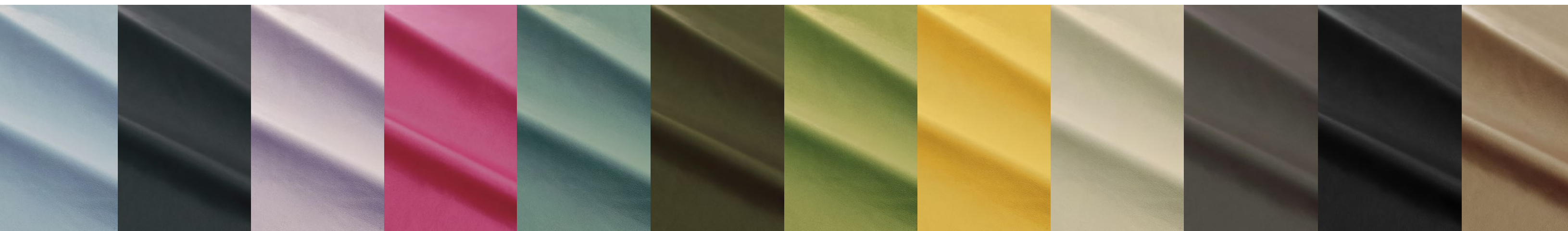

S - 9 9623 S - 9 9624 S - 9 9625 S - 9 9626 S - 9 9627 S - 9 9628 S - 9 9629 S - 9 9630 S - 9 9631 S - 9 9632 S - 9 9633 S - 9 9634



S - 9 9636 *testa di moro* S - 9 9635 *cognac* S - 9 9637 *verde* S - 9 9638 *borderux* S - 9 9639 *negro*

References	Leather Thickness	Bending Resistance	Tear Resistance	Cleaning
S - 9 9600 a 9634	1,2 - 1,4 mm	> 50000 cycles ISO 5402	> 20 N ISO 3377-1	The cleaning of the leather, must be with water and neutral PH soap or specific products for leather care. <i>La limpieza de la piel, debe hacerse con agua y jabón neutro o productos aptos para la piel.</i>
S - 9 9635 a 9639	1 mm	> 50000 cycles ISO 5402	52 N ISO 3377-1	Le nettoyage du cuir doit être fait avec de l'eau et de savon neutre ou de produits spéciaux pour le cuir.

Los colores de los tejidos, polipiel y pieles pueden variar de una partida a otra. / The colors of the fabrics, synthetic leather and leather may differ from one consignment to the next. / Les couleurs des tissus, des cuirs synthétiques et des cuirs, ils peuvent varier d'une commande à une autre.

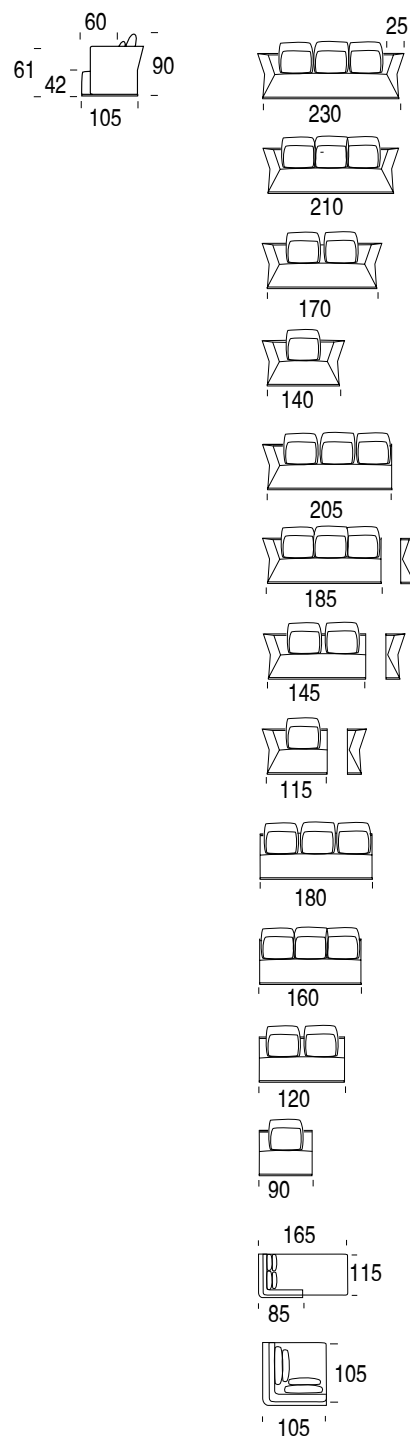

REF.

9404P

9403P

9402P

9401P

940M4

940M3

940M2

940M1

9404S

9403S

9402S

9401S

940CH

940RI

OPTIONS / OPCIONES / OPTIONS

LEGS / PATAS / PIEDS



REMOVABLE / DESENFUNDABLE / DÉHOUSSABLE

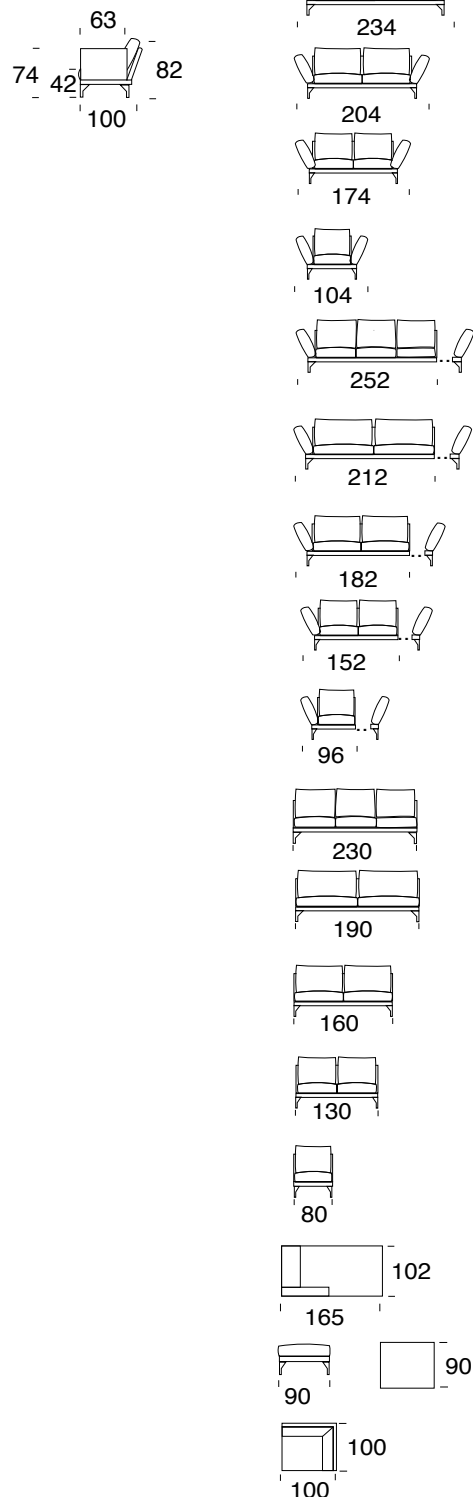

REF.

9635P

9634P

9633P

9632P

9631P

963M5

963M4

963M3

963M2

963M1

9635S

9634S

9633S

9632S

9631S

963CH

963PF

963RI

OPTIONS / OPCIONES / OPTIONS

LEGS / PATAS / PIEDS



MECHANISM / MECANISMO / MÉCANISME

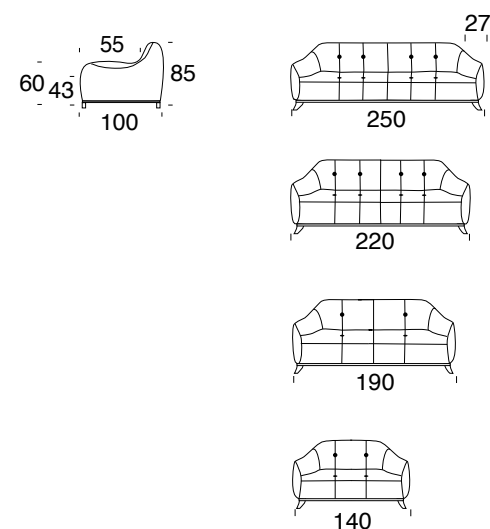
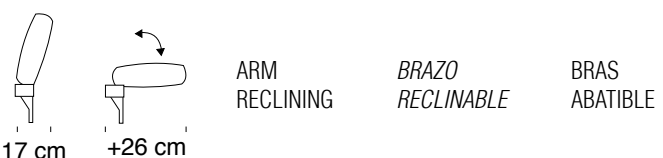

REF.

9834P

9833P

9832P

983EP

. IMPORTANT: To choose fabric, consult us.
. IMPORTANTE: Para elegir tejido, consulte con fábrica.
. IMPORTANT: Pour choisir tissu, consulter avec l'usine.

OPTIONS / OPCIONES / OPTIONS

LEGS / PATAS / PIEDS

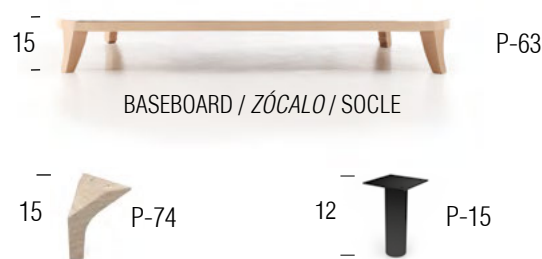

FINISHES / ACABADOS / FINITIONS

P-63	P-74	WENGUE		
P-63	P-74	CHERRY	CEREZO	MERISIER
P-63	P-74	WALNUT	NOGAL	NOYER
P-63		OAK	ROBLE	CHÊNE
P-74		ASH	FRESNO	FRÊNE
P-15		CHROMED	CROMADO	CHROMÉ
P-15		BLACK	NEGRO	NOIR

BUTTON / BOTÓN / BOUTON

Upholstered button in pulls. Specify the color of the button fabric. Two colors upholsterable.

Botón tapizado en los tirones. Especificar el color del tejido del botón. Tapizable en dos colores.

Bouton tapissé dans les tires. Spécifier la couleur du tissu du bouton. Tapissé en deux couleurs.

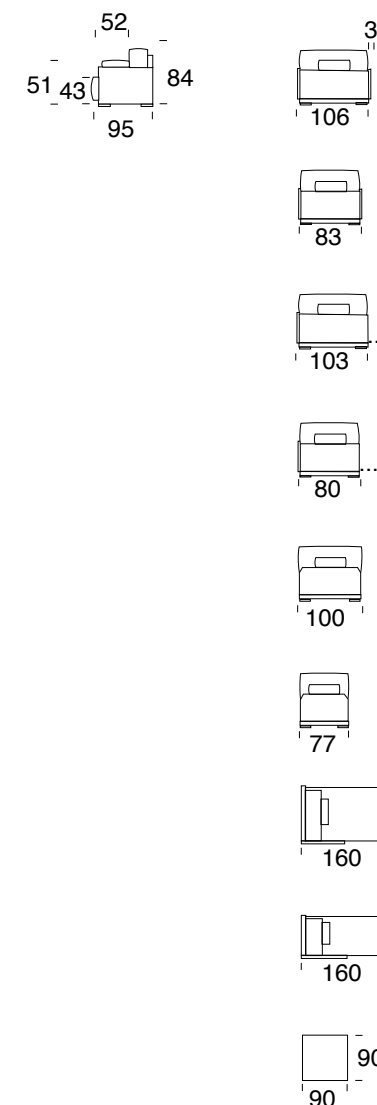
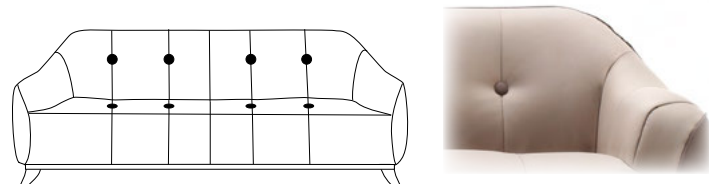

REF.

964EP

9641P

9641E

9641M

964ES

9641S

964CS

964CH

964PF

OPTIONS / OPCIONES / OPTIONS

LEGS / PATAS / PIEDS



FINISHES / ACABADOS / FINITIONS

P-42 WENGUE

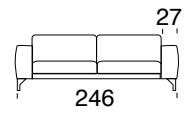

REF.

9874P

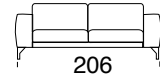

9873P

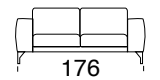

9872P

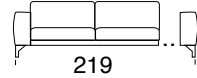

987M4

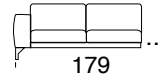

987M3

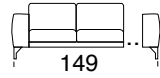

987M2

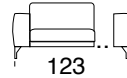

987ME

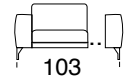

987M1

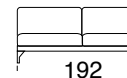

9874S

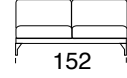

9873S

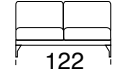

9872S

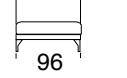

9871E

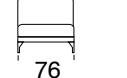

9871S



987CH

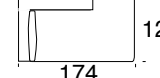

987CS



987CT

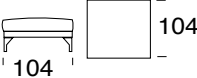

987PE



987P1

OPTIONS / OPCIONES / OPTIONS

LEGS / PATAS / PIEDS

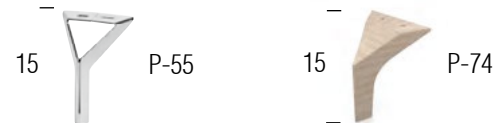

REMOVABLE / DESENFUNDABLE / DÉHOUSSABLE



REF.

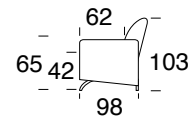

9843P

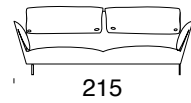

9842P

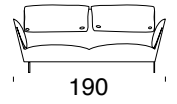

984BU

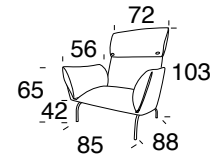

984RP

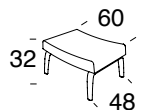

. IMPORTANT: To choose fabric, consult us.
. IMPORTANTE: Para elegir tejido, consulte con fábrica.
. IMPORTANT: Pour choisir tissu, consulter avec l'usine.

OPTIONS / OPCIONES / OPTIONS

LEGS / PATAS / PIEDS



FINISHES / ACABADOS / FINITIONS

P-64	P-66	STAINLESS STEEL	ACERO INOX	ACIER INOX
P-64	P-66	WHITE	BLANCO	BLANC
P-64	P-66	BLACK	NEGRO	NOIR
P-65	P-67	WALNUT	NOGAL	NOYER
P-65	P-67	ASH	FRESNO	FRÊNE
P-65	P-67	WENGUE		
P-65	P-67	CHERRY	CEREZO	MERISIER

BUTTON / BOTON / BOUTON

-Upholstered button in pulls. Specify the color of the button fabric.
-Botón tapizado en los tirones. Especificar el color del tejido del botón.
-Bouton tapissé dans le tirers. Spécifier la couleur du tissu du bouton.



Reclining back.

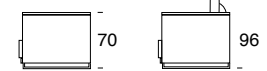

REF.

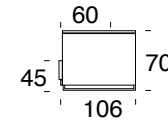

9724P

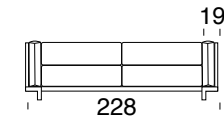

9723P

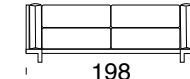

9722P

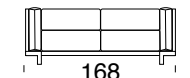

972M4

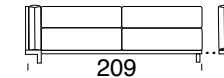

972M3

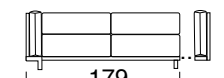

972M2

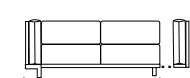

9724S

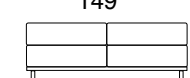

9723S

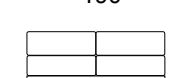

9722S

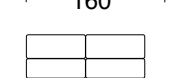

972CS

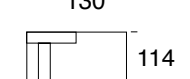

972CH

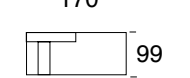

972PF

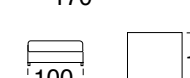

972RI

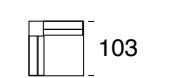

OPTIONS / OPCIONES / OPTIONS

LEGS / PATAS / PIEDS



FINISHES / ACABADOS / FINITIONS

P-59	STAINLESS STEEL	ACERO INOX	ACIER INOX
------	-----------------	------------	------------



REF.

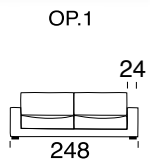

9694P

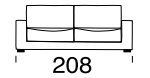

9693P



9691A



9691P

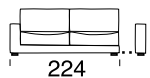

969M4

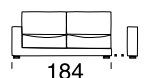

969M3



969MA



969M1

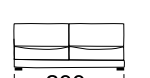

9694S

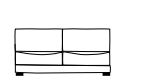

9693S



969SA



9691S

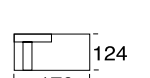

969CS

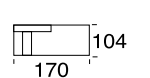

969CH

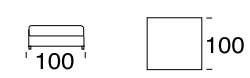

969PF

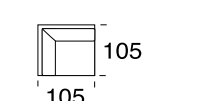

969RI

OPTIONS / OPCIONES / OPTIONS

LEGS / PATAS / PIEDS



HIDE / OCULTA

REMOVABLE / DESENFUNDABLE / DÉHOUSSABLE

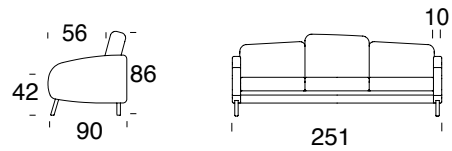

REF.

9894P

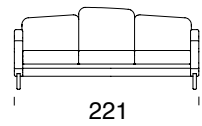

9893P

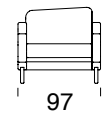

9891E

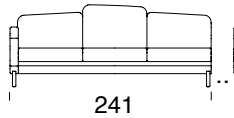

989M4

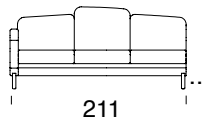

989M3

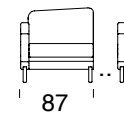

989ME

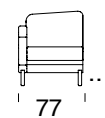

989M1

OPTIONS / OPCIONES / OPTIONS

LEGS / PATAS / PIEDS

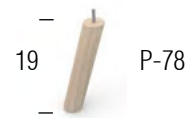

FINISHES / ACABADOS / FINITIONS

P-78	WENGUE		
P-78	CHERRY	CEREZO	MERISIER
P-78	OAK	ROBLE	CHÊNE
P-78	WALNUT	NOGAL	NOYER

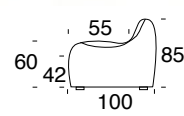

REF.

9714P

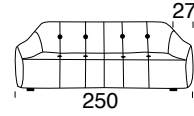

9713P

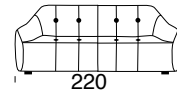

9712P

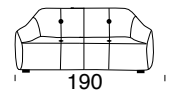

971EP

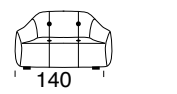

9711P

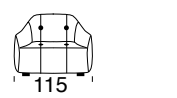

971M4

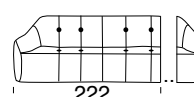

971M3

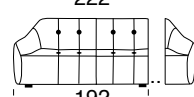

971M2

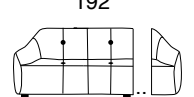

971M1

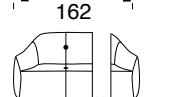

9714S

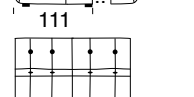

9713S

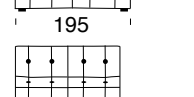

9712S

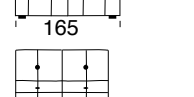

9711S

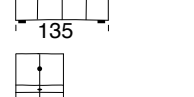

971CS

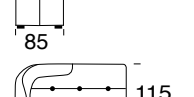

971CH

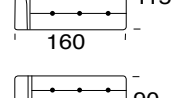

971RI

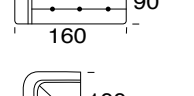

971PF

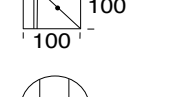

OPTIONS / OPCIONES / OPTIONS

LEGS / PATAS / PIEDS



OP.1
(3 cushions)

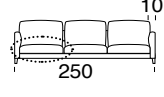

OP.2
(1 cushion)

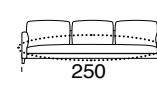

REF.

9805P

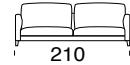

9804P

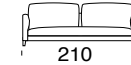

9803P



9802P

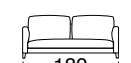

9801P



980TA



980TB



980M5

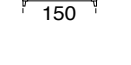

980M4



980M3



980M2

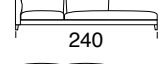

980M1

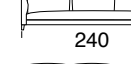

980M5



980M4

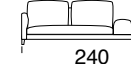

980M4



980M3



980M2

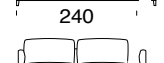

980M1



980M5



980M4



980M3

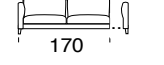

980M2



980M1



9805S

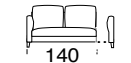

9804S



9804S



9803S



9802S



9801S

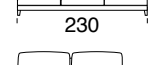

980TC

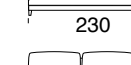

980TD

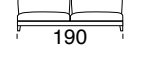

980TF

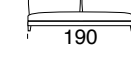

980RI

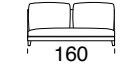

OPTIONS / OPCIONES / OPTIONS

LEGS / PATAS / PIEDS



REMOVABLE / DESENFUNDABLE / DÉHOUSSABLE



REF.

9814P

9813P

9812P

9811P

981M4

981M3

981M2

981M1

9814S

9813S

9812S

9811S

981CS

981TA

981PR

981RI

OPTIONS / OPCIONES / OPTIONS

LEGS / PATAS / PIEDS



FINISHES / ACABADOS / FINITIONS

P-25	P42	WENGUE	
P-25	CHERRY	CEREZO	MERISIER
P-25	OAK	ROBLE	CHÊNE
P-52	CHROMED	CROMADO	CHROMÉ

REMOVABLE / DESENFUNDABLE / DÉHOUSSABLE

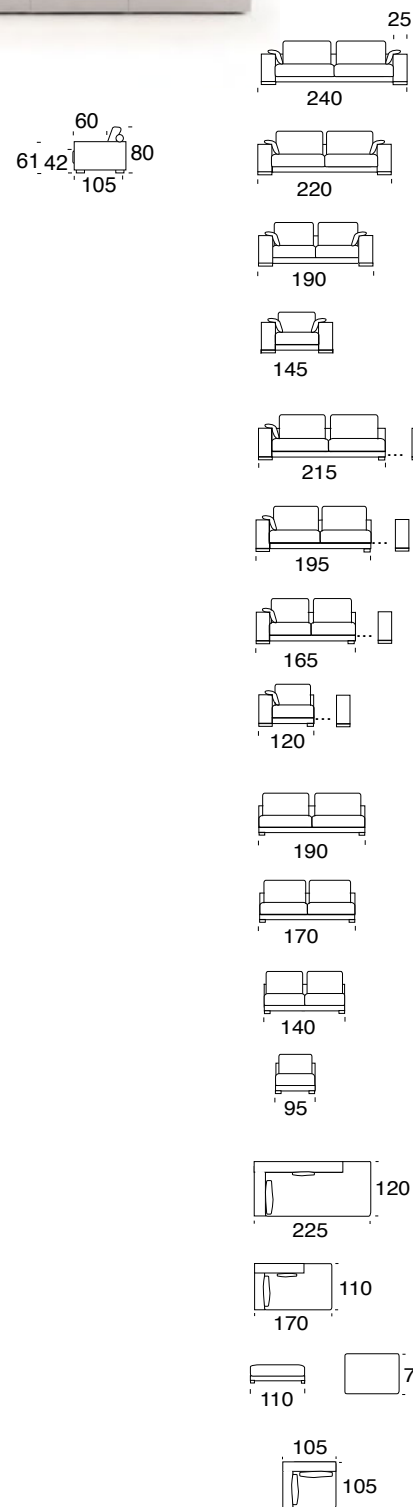

REF.

9544P

9543P

9542P

9541P

954M4

954M3

954M2

954M1

9544S

9543S

9542S

9541S

954CS

954CH

954PF

954RI

OPTIONS / OPCIONES / OPTIONS

LEGS / PATAS / PIEDS



FINISHES / ACABADOS / FINITIONS

P-25	P42	WENGUE		
P-25		CHERRY	CEREZO	MERISIER
P-25		OAK	ROBLE	CHÊNE
P-52		CHROMED	CROMADO	CHROMÉ

REMOVABLE / DESENFUNDABLE / DÉHOUSSABLE

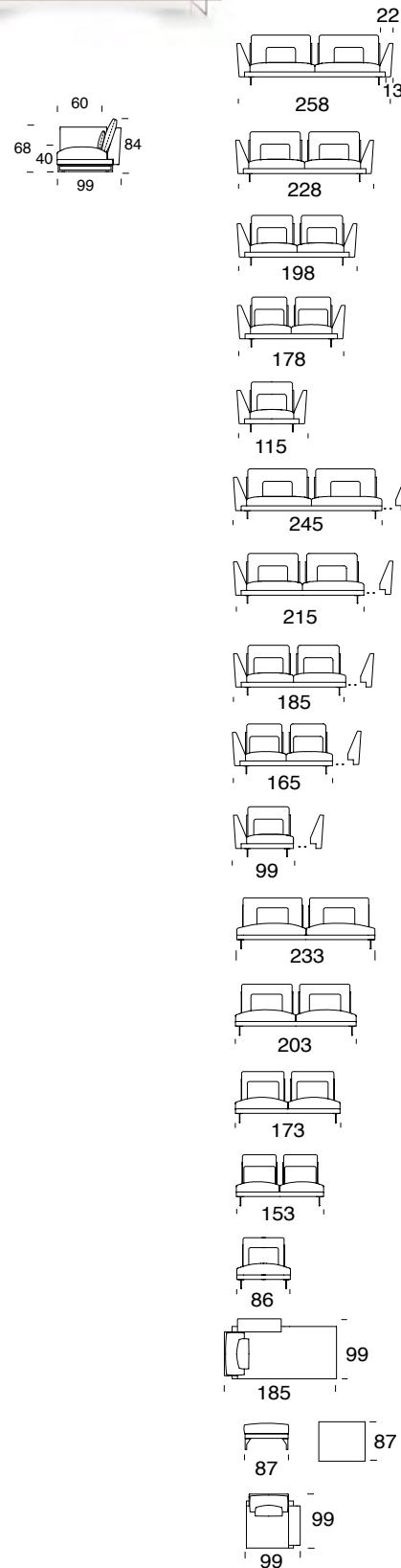

REF.

9885P

9884P

9883P

9882P

9881P

988M5

988M4

988M3

988M2

988M1

9885S

9884S

9883S

9882S

9881S

988CH

988PF

988RI

OPTIONS / OPCIONES / OPTIONS

LEGS / PATAS / PIEDS



FINISHES / ACABADOS / FINITIONS

P-79	STAINLESS STEEL	ACERO INOX	ACIER INOX
P-80	BLACK	NEGRO	NOIR
P-80	WHITE	BLANCO	BLANC

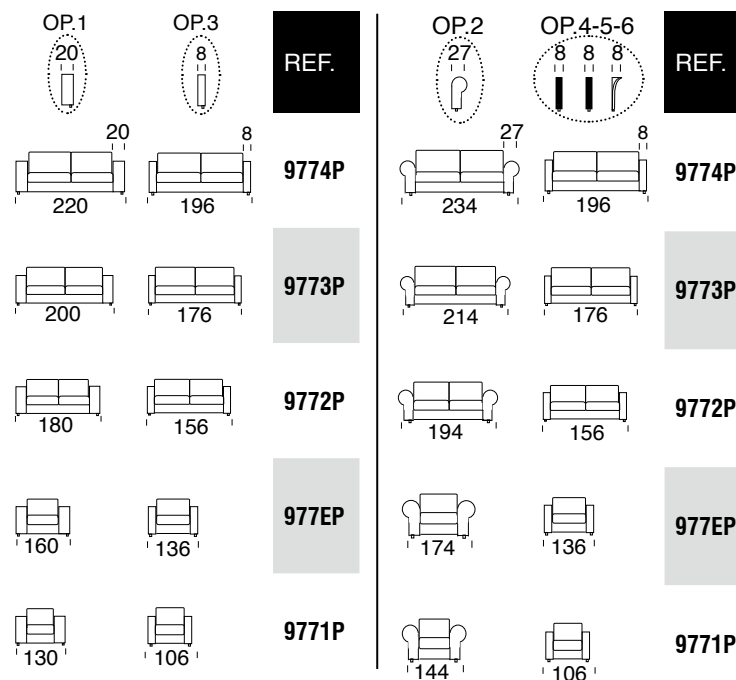
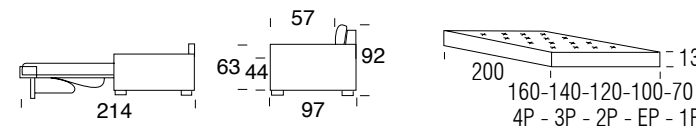

OPTIONS / OPCIONES / OPTIONS

WHEEL REMOVABLE SYSTEM / SISTEMA DE RUEDAS EXTRAIBLES

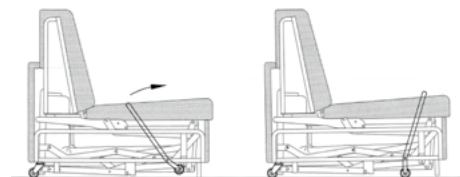

.Using the lever of the lifting system, wheels appear and elevate the sofa which allow to move it easily. /
 .Mecanismo de elevación por el que con tan solo accionar la palanca aparecen unas ruedas que elevan el sofá cama y permiten desplazarlo fácilmente. /
 .Mécanisme d'élévation selon lequel il faut seulement lever le levier pour avoir des roues qui soulèvent le canapé-lit et vous permettent de le déplacer facile-

MATTRESS / COLCHON / MATELAS

VISCOELASTIC VISCOELASTICA MÉMOIRE

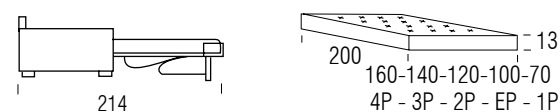

LEGS / PATAS / PIEDS

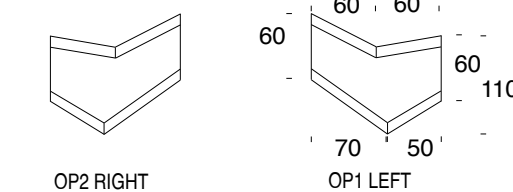
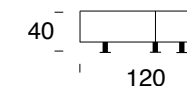
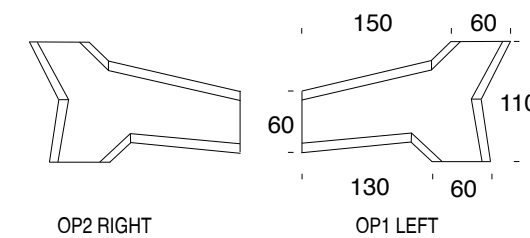
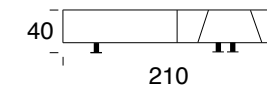

OPTIONS / OPCIONES / OPTIONS

EXAMPLES OF COMPOSITIONS / EJEMPLO DE COMPOSICIONES

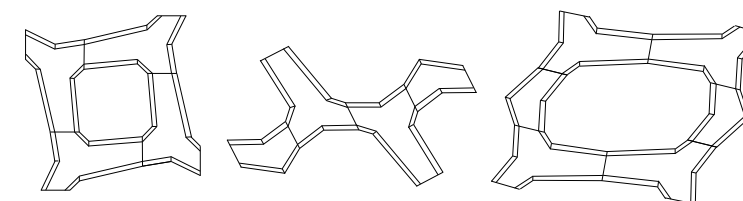

REF.

975B1

REF.

975B2

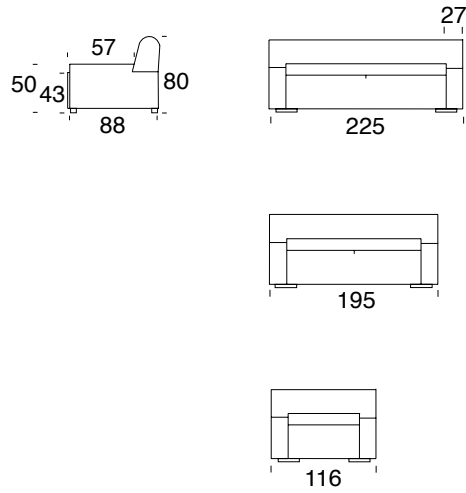

REF.

9634P

9633P

9631P

OPTIONS / OPCIONES / OPTIONS

LEGS / PATAS / PIEDS



FINISHES / ACABADOS / FINITIONS

P-75	CHROMED	CROMADO	CHROMÉ
P-42	WENGUE		

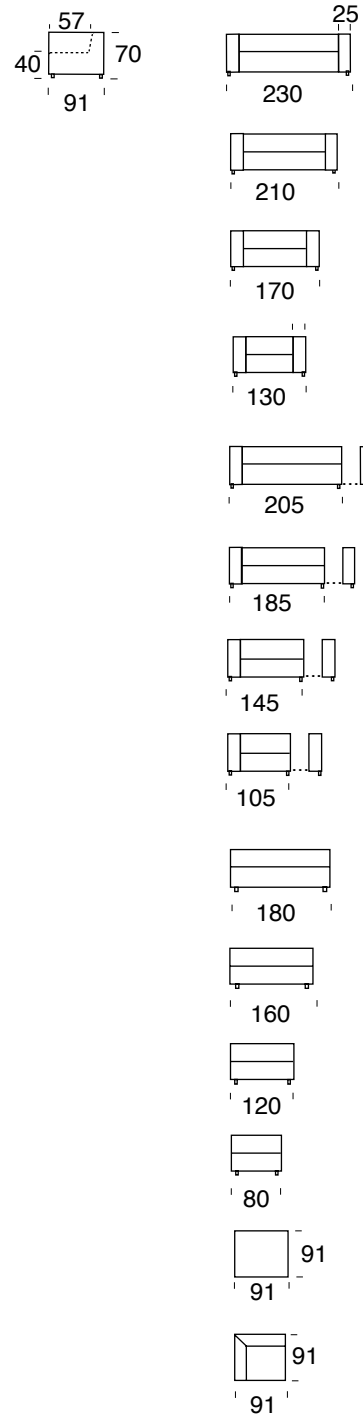

REF.

9454P

9453P

9452P

9451P

945M4

945M3

945M2

945M1

9454S

9453S

9452S

9451S

945PF

945RI

OPTIONS / OPCIONES / OPTIONS

LEGS / PATAS / PIEDS



FINISHES / ACABADOS / FINITIONS

P-25	P42	WENGUE		
P-25		CHERRY	CEREZO	MERISIER
P-25		OAK	ROBLE	CHÊNE
P-52		CHROMED	CROMADO	CHROMÉ

LIVE M1

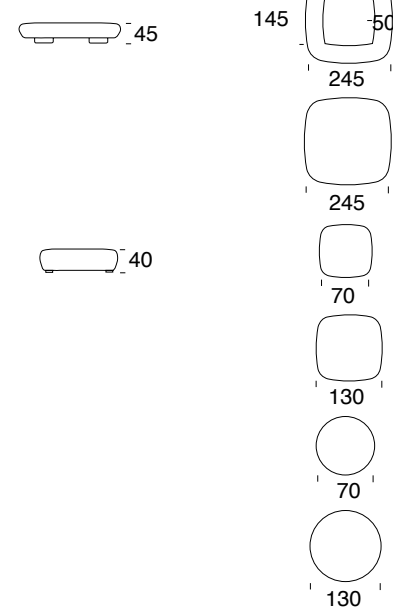

REF.

940T4

OP. LEDS

940C4

940C1

940C2

940R1

940R2

LIVE M2

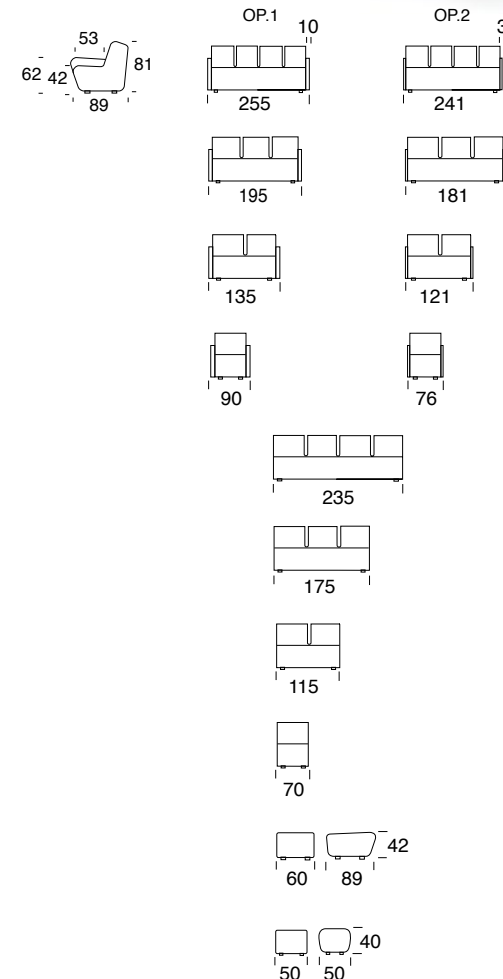

REF.

9584P

9583P

9582P

9581P

9584S

9583S

9582S

9581S

958PL

958PF

OPTIONS / OPCIONES / OPTIONS

LEGS / PATAS / PIEDS



ALL MODELS EXCEPT 940T4 /
TODOS LOS MODELOS EXCEPTO 940T4 /
TOUTS LES MODELES SAUF 940T4

ONLY MODEL 940T4 /
SOLO MODELO 940T4 /
SEULEMENT LE MODÈLE 940T4

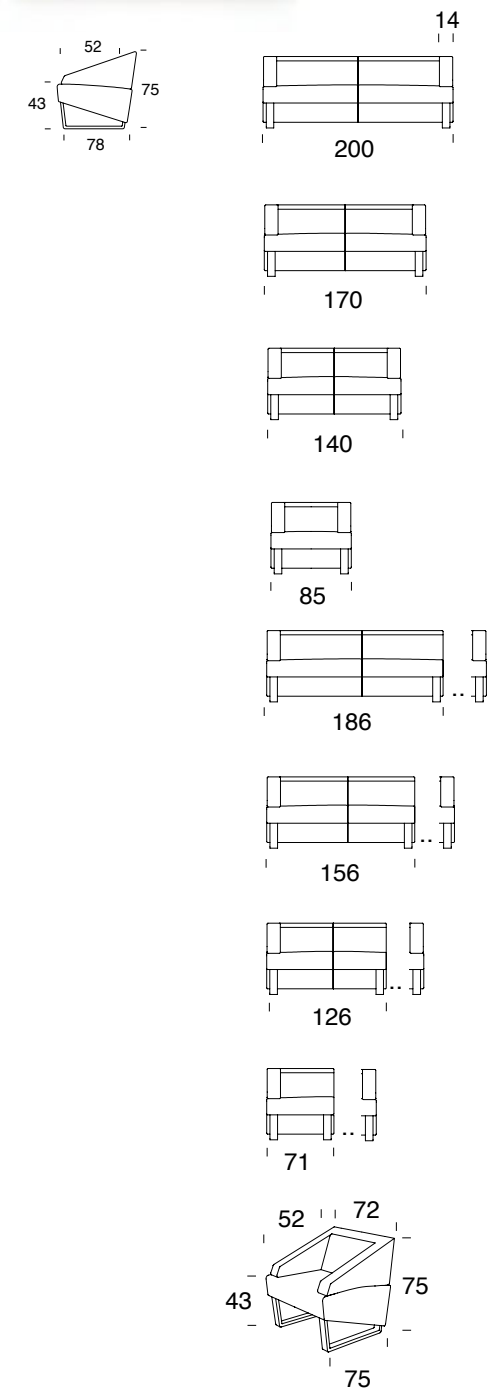

REF.

9904P

9903P

9902P

9901P

990M4

990M3

990M2

990M1

990BU

OPTIONS / OPCIONES / OPTIONS

LEGS / PATAS / PIEDS

STEEL / ACERO / ACIER

WOOD / MADERA / BOIS



FINISHES / ACABADOS / FINITIONS

P-76	STAINLESS STEEL	ACERO INOX	ACIER INOX
P-77	WENGUE		
P-77	CHERRY	CEREZO	MERISIER
P-77	OAK	ROBLE	CHÊNE
P-77	WALNUT	NOGAL	NOYER

HIDE

92

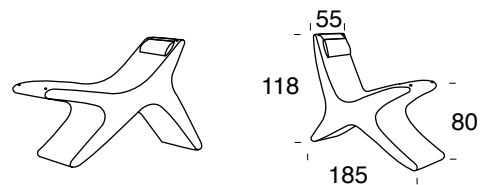

REF.

1291P

. **IMPORTANT:** To choose fabric, consult us.
 . **IMPORTANTE:** Para elegir tejido, consulte con fábrica.
 . **IMPORTANT:** Pour choisir tissu, consulter avec l'usine.

INSIDE

91

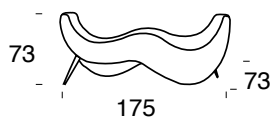

REF.

1251P

. **IMPORTANT:** To choose fabric, consult us.
 . **IMPORTANTE:** Para elegir tejido, consulte con fábrica.
 . **IMPORTANT:** Pour choisir tissu, consulter avec l'usine.

OPTIONS / OPCIONES / OPTIONS

FINISHES LEGS / ACABADOS PATAS / FINITIONS PIEDS

HANDLE LEG OPTION OPCION PATA MADERA OPTION PIED BOIS	WENGUE		
	CHERRY	CEREZO	MERISIER
	OAK	ROBLE	CHÊNE
	WALNUT	NOGAL	NOYER
AISI 304	AISI 304 STEEL	ACERO AISI 304	ACIER AISI 304

NOMI

93

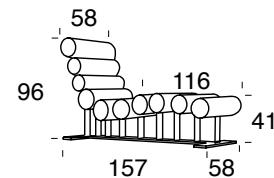

REF.

908CH

. **IMPORTANT:** To choose fabric, consult us.
 . **IMPORTANTE:** Para elegir tejido, consulte con fábrica.
 . **IMPORTANT:** Pour choisir tissu, consulter avec l'usine.

ARKO

86

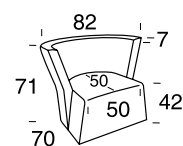

SWIVEL / GIRATORIO / PIVOTANT

REF.

940BU

940BG

OPTIONS / OPCIONES / OPTIONS

LEGS / PATAS / PIEDS

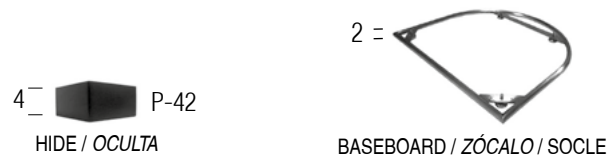

REMOVABLE / DESENFUNDABLE / DÉHOUSSABLE



BOSS

78



OP1



OP2

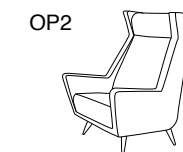
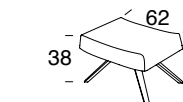
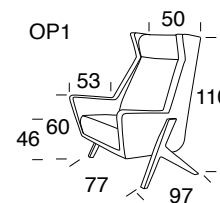

REF.

976BU

976RU

976BB

OPTIONS / OPCIONES / OPTIONS

FINISHES / ACABADOS / FINITIONS

OP1, OP2	WENGUE		
OP1, OP2	CHERRY	CEREZO	MERISIER
OP1, OP2	OAK	ROBLE	CHÊNE

DELP

87

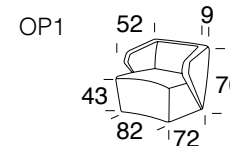

FIXED / FIJO / FIXE



SWIVEL / GIRATORIO / PIVOTANT

REF.

975B1

975B2

OPTIONS / OPCIONES / OPTIONS

LEGS OP1 / PATAS OP1 / PIEDS OP1



FINISHES / ACABADOS / FINITIONS

P-42	WENGUE
------	--------

DIBA

81



REF.

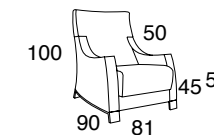

948BA

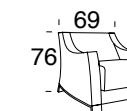

948BB

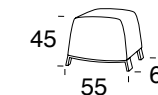

948PF

OPTIONS / OPCIONES / OPTIONS

PATAS / LEGS / PIEDS



REMOVABLE / DESENFUNDABLE / DÉHOUSSABLE

EVEN

77

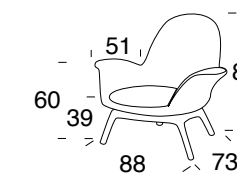

REF.

985BU

OPTIONS / OPCIONES / OPTIONS

LEGS / PATAS / PIEDS



FINISHES / ACABADOS / FINITIONS

WENGUE		
CHERRY	CEREZO	MERISIER
ASH	FRESNO	FRÊNE
WALNUT	NOGAL	NOYER



. MINIMUM ORDER 10 UNITS.
. PEDIDO MÍNIMO 10 UNIDADES DE LA MISMA REFERENCIA.
. COMMANDE MINIMUM DE 10 UNITÉS DE LA MÊME RÉFÉRENCE.

REF.

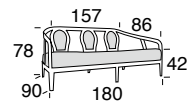

5033T

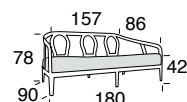

5033P

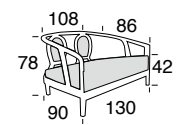

5032T

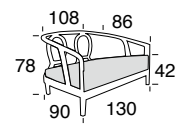

5032P

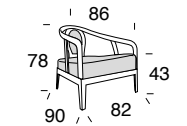

503BT

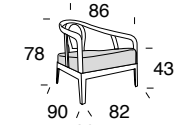

503BA

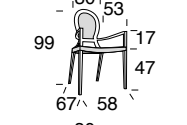

503ST

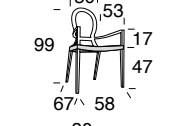

503SA

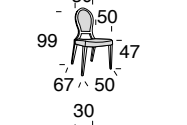

5031T

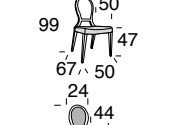

5031A

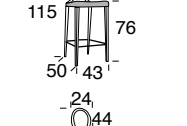

503TT



503TA

OPTIONS / OPCIONES / OPTIONS

FINISHES / ACABADOS / FINITIONS

WENGUE		
CHERRY	CEREZO	MERISIER
OAK	ROBLE	CHÊNE
MATT BLACK	NEGRO MATE	BLANC MAT
MATT WHITE	BLANCO MATE	NOIR MAT



REF.

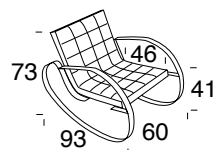

9091P

OPTIONS / OPCIONES / OPTIONS

FINISHES / ACABADOS / FINITIONS

WENGUE		
CHERRY	CEREZO	MERISIER
OAK	ROBLE	CHÊNE
MATT BLACK	NEGRO MATE	BLANC MAT
MATT WHITE	BLANCO MATE	NOIR MAT
LEATHER	PIEL	CUIR



REF.

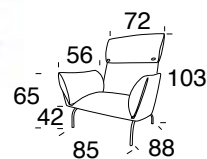

984BU

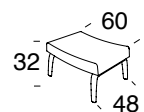

984RP

OPTIONS / OPCIONES / OPTIONS

LEGS / PATAS / PIEDS

STEEL / ACERO / ACIER	WOOD / MADERA / BOIS
 P-66	 P-67

BUTTON / BOTON / BOUTON

-Upholstered button in pulls. Specify the color of the button fabric.
-Botón tapizado en los tirones. Especificar el color del tejido del botón.
-Bouton tapissé dans le tirers. Spécifier la couleur du tissu du bouton.



REF.

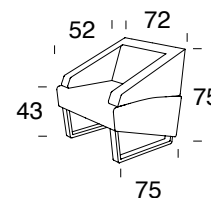

990BU

OPTIONS / OPCIONES / OPTIONS

LEGS / PATAS / PIEDS

STEEL / ACERO / ACIER	WOOD / MADERA / BOIS
 P-76 ARMCHAIR	 P-77 ARMCHAIR

FINISHES / ACABADOS / FINITIONS

P-76	STAINLESS STEEL	ACERO INOX	ACIER INOX
P-77	WENGUE		
P-77	CHERRY	CEREZO	MERISIER
P-77	OAK	ROBLE	CHÊNE
P-77	WALNUT	NOGAL	NOYER



REF.

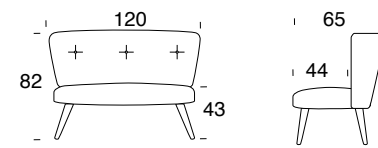

9862B

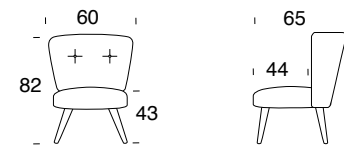

986BU

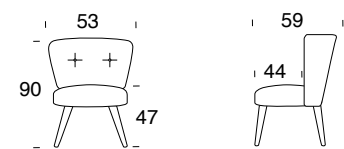

986SI

OPTIONS / OPCIONES / OPTIONS

FINISHES / ACABADOS / FINITIONS

WENGUE		
CHERRY	CEREZO	MERISIER
OAK	ROBLE	CHÊNE
WALNUT	NOGAL	NOYER



REF.

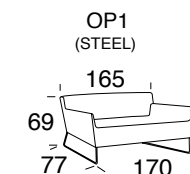

9613B

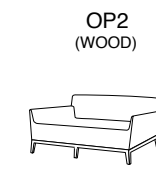

9612B

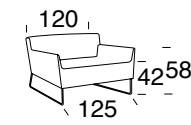

961BU

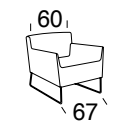

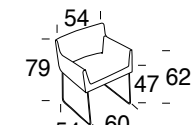

961SI



OPCIONES / OPTIONS / OPTIONS

LEGS / PATAS / PIEDS

 OP1 STEEL / ACERO / ACIER	 OP2 WOOD / MADERA / BOIS
---	--

FINISHES / ACABADOS / FINITIONS

OP1	STAINLESS STEEL	ACERO INOX	ACIER INOX
OP1	MATT WHITE	BLANCO MATE	BLANC MAT
OP1	MATT BLACK	NEGRO MATE	NOIR MAT
OP2	WENGUE		
OP2	CHERRY	CEREZO	MERISIER
OP2	OAK	ROBLE	CHÊNE
OP2	WALNUT	NOGAL	NOYER

BUTTON / BOTON / BOUTON

.Upholstered button in pulls. Specify the color of the button fabric.
.Botón tapizado en los tirones. Especificar el color del tejido del botón.
.Bouton tapissé dans le tirers. Spécifier la couleur du tissu du bouton.



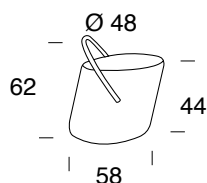

REF.

966BU

OPTIONS / OPCIONES / OPTIONS

FINISHES BACK REST / ACABADOS RESPALDO / FINITIONS DOSSIER

HANDLE WOOD OPTION OPCIÓN ASA DE MADERA OPTION EN BOIS	WENGUE		
	CHERRY	CEREZO	MERISIER
	OAK	ROBLE	CHÊNE
AISI 304	AISI 304 STEEL	ACERO AISI 304	ACIER AISI 304



REF.

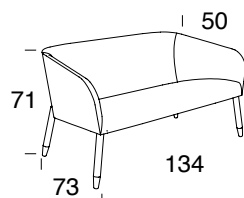

9912P

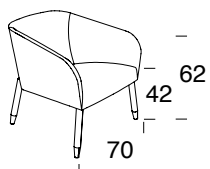

991BU

OPTIONS / OPCIONES / OPTIONS

FINISHES / ACABADOS / DÉHOUSSABLE

WENGUE		
CHERRY	CEREZO	MERISIER
OAK	ROBLE	CHÊNE



REF.

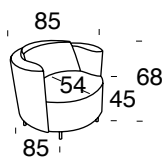

946B1



946B2

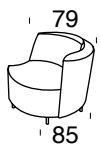

946B3

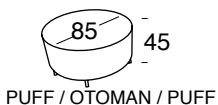

PUFF / OTOMAN / PUFF

946P1



PUFF / OTOMAN / PUFF

946P2

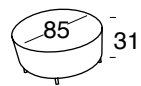

MESA / TABLE / TABLE

946M1



MESA / TABLE / TABLE

946M2

EXAMPLES / EJEMPLOS / EXEMPLES

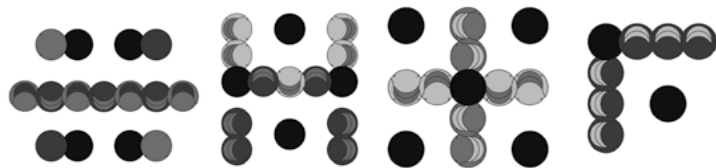

OPTIONS / OPCIONES / OPTIONS

FINISHES / ACABADOS / DÉHOUSSABLE

LAQUERED / LACADO / LAQUÉ

BLACK, WHITE, RED,	NEGRO, BLANCO, ROJO,	NOIR, BLANC, ROUGE,
STONE, GREY, SEA, GREEN,	PIEDRA, GRIS, MAR, VERDE	PIERRE, GREY, MER, VERT,
FUCHSIA, ORANGE.	FUCSIA, NARANJA.	FUCHSIA, ORANGE.
SEE FINISHES TABLE ENCLOSED.	VER TABLA DE ACABADOS	VOIR TABLEAU DES FINITIONS.
ANTI SCRATCH	ANTIRALLADURA	ANTIRÂPURE



Ref. 950BU

Ref. 950BZ

Ref. 950BC

REF.

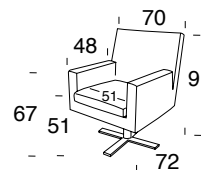

950BU

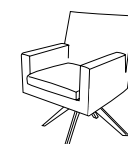

950BZ



950BC

OPTIONS / OPCIONES / OPTIONS

REMOVABLE / DESENFUNDABLE / DÉHOUSSABLE



REF.

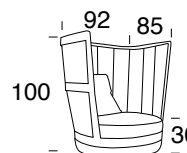

978BU

- . **IMPORTANT:** To choose fabric, consult us.
- . **IMPORTANTE:** Para elegir tejido, consulte con fábrica.
- . **IMPORTANT:** Pour choisir tissu, consulter avec l'usine.

OPTIONS / OPCIONES / OPTIONS

STRUCTURE FINISHES / ACABADOS ESTRUCTURA / FINITIONS DU STRUCTURE

WHITE SHINE OR MATT	BLANCO BRILLO O MATE	BLANC BRILLIANT OU MAT
BLACK SHINE OR MATT	NEGRO BRILLO O MATE	NOIR BRILLIANT OU MAT

ASK FOR AVAILABLE COLOURS BY QUANTITY.
CONSULTE DISPONIBILIDAD DE COLORES POR CANTIDADES
CONSULTER DISPONIBILITÉ DE COULEURS POUR QUANTITÉS



REF.

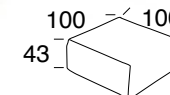

97310

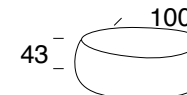

9731R

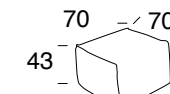

97370

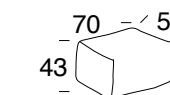

97375

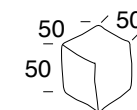

97350

DODU - CUSHIONS Arbel

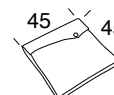

REF.

97480

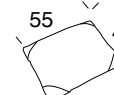

974ES



974DB

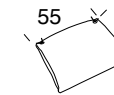

974ME

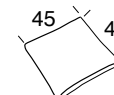

969CO



940RE

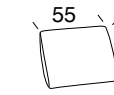

940CO

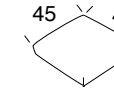

955CO

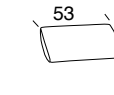

964CO

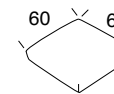

970CO



REF.

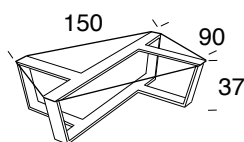

83116

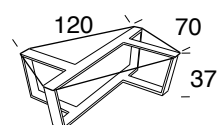

83112

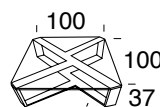

83110

OPTIONS / OPCIONES / OPTIONS

FINISHES / ACABADOS / FINITIONS

WOOD / MADERA / BOIS

WENGUE

CHERRY CEREZO MERISIER

OAK ROBLE CHÊNE

WALNUT NOGAL NOYER

LAQUERED / LACADO / LAQUE

BLACK, WHITE, RED, NEGRO, BLANCO, ROJO NOIR, BLANC, ROUGE

STONE, GREY, SEA PIEDRA, GRIS, MAR, VERDE PIERRE, GREY, MER

GREEN, FUCHSIA, ORANGE FUCSIA, NARANJA VERT, FUCHSIA, ORANGE

SEE FINISHES TABLE ENCLOSED VER TABLA DE ACABADOS VOIR TABLEAU DES FINITIONS

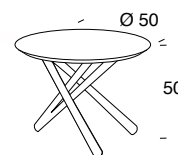

REF.

83250

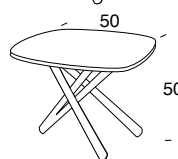

83251

OPTIONS / OPCIONES / OPTIONS

FINISHES / ACABADOS / FINITIONS

WOOD / MADERA / BOIS

WENGUE

CHERRY CEREZO MERISIER

OAK ROBLE CHÊNE

WALNUT NOGAL NOYER

LAQUERED / LACADO / LAQUE

BLACK, WHITE, RED, NEGRO, BLANCO, ROJO NOIR, BLANC, ROUGE

STONE, GREY, SEA PIEDRA, GRIS, MAR, VERDE PIERRE, GREY, MER

GREEN, FUCHSIA, ORANGE FUCSIA, NARANJA VERT, FUCHSIA, ORANGE

SEE FINISHES TABLE ENCLOSED VER TABLA DE ACABADOS VOIR TABLEAU DES FINITIONS



REF.

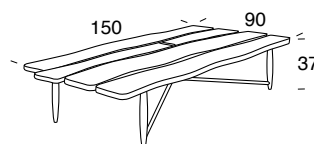

83315

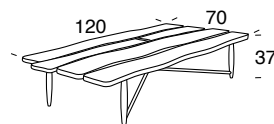

83312

OPTIONS / OPCIONES / OPTIONS

FINISHES / ACABADOS / FINITIONS

WENGUE

CHERRY CEREZO MERISIER

OAK ROBLE CHÊNE

WALNUT NOGAL NOYER



REF.

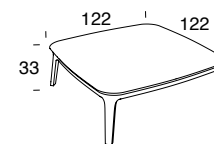

98512

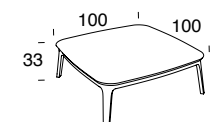

98510

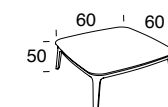

83460

OPTIONS / OPCIONES / OPTIONS

FINISHES / ACABADOS / FINITIONS

WOOD / MADERA / BOIS

WENGUE

CHERRY CEREZO MERISIER

OAK ROBLE CHÊNE

WALNUT NOGAL NOYER

MARBLE / MARMOL / MARBRE

WHITE BLANCO BLANC

BLACK NEGRO NOIR

BROWN MARRÓN IMPERIAL BRUN

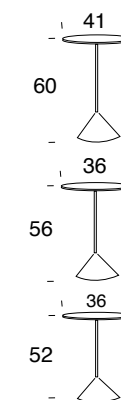

REF.

83840

83847

83844

OPTIONS / OPCIONES / OPTIONS

FINISHES / ACABADOS / FINITIONS

WOOD / MADERA / BOIS

WENGUE

CHERRY CEREZO MERISIER

SYCAMORE SICOMORO SYCOMORE

WALNUT NOGAL NOYER

LAQUERED / LACADO / LAQUE

BLACK, WHITE, RED, NEGRO, BLANCO, ROJO NOIR, BLANC, ROUGE

STONE, GREY, SEA PIEDRA, GRIS, MAR, VERDE PIERRE, GREY, MER

GREEN, FUCHSIA, ORANGE FUCSIA, NARANJA VERT, FUCHSIA, ORANGE

SEE FINISHES TABLE ENCLOSED VER TABLA DE ACABADOS VOIR TABLEAU DES FINITIONS



REF.

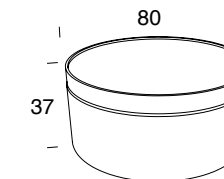

83780

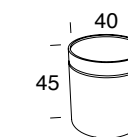

83740

OPTIONS / OPCIONES / OPTIONS

FINISHES / ACABADOS / FINITIONS

WALNUT NOGAL NOYER

ASH FRESNO FRÊNE

WENGUE



. MINIMUM ORDER 10 UNITS.
 . PEDIDO MÍNIMO 10 UNIDADES DE LA MISMA REFERENCIA.
 . COMMANDE MINIMUM DE 10 UNITÉS DE LA MÊME RÉFÉRENCE.

REF.

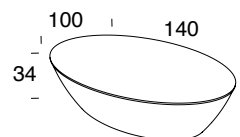

83914

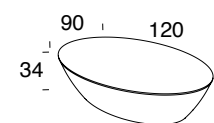

83912

OPTIONS / OPCIONES / OPTIONS

FINISHES / ACABADOS / FINITIONS

WOOD / MADERA / BOIS

WENGUE

CHERRY	CEREZO	MERISIER
OAK	ROBLE	CHÊNE
WALNUT	NOGAL	NOYER

MARBLE / MARMOL / MARBRE

WHITE	BLANCO	BLANC
BLACK	NEGRO	NOIR
BROWN	MARRÓN IMPERIAL	BRUN

LAQUERED / LACADO / LAQUE

BLACK, WHITE, RED,	NEGRO, BLANCO, ROJO	NOIR, BLANC, ROUGE
--------------------	---------------------	--------------------

STONE, GREY, SEA	PIEDRA, GRIS, MAR, VERDE	PIERRE, GREY, MER
------------------	--------------------------	-------------------

GREEN, FUCHSIA, ORANGE	FUCSIA, NARANJA	VERT, FUCHSIA, ORANGE
------------------------	-----------------	-----------------------

SEE FINISHES TABLE ENCLOSED	VER TABLA DE ACABADOS	VOIR TABLEAU DES FINITIONS
-----------------------------	-----------------------	----------------------------

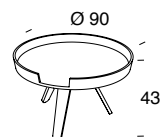

REF.

84190

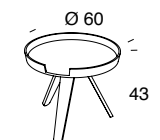

84160

OPTIONS / OPCIONES / OPTIONS

FINISHES / ACABADOS / FINITIONS

WOOD / MADERA / BOIS

WENGUE

CHERRY	CEREZO	MERISIER
OAK	ROBLE	CHÊNE
WALNUT	NOGAL	NOYER

LAQUERED / LACADO / LAQUE

BLACK, WHITE, RED,	NEGRO, BLANCO, ROJO	NOIR, BLANC, ROUGE
STONE, GREY, SEA	PIEDRA, GRIS, MAR, VERDE	PIERRE, GREY, MER

GREEN, FUCHSIA, ORANGE	FUCSIA, NARANJA	VERT, FUCHSIA, ORANGE
------------------------	-----------------	-----------------------

SEE FINISHES TABLE ENCLOSED	VER TABLA DE ACABADOS	VOIR TABLEAU DES FINITIONS
-----------------------------	-----------------------	----------------------------

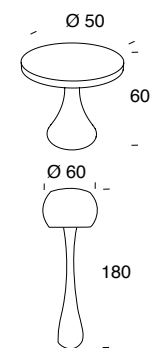

REF.

836ME

836LA

OPTIONS / OPCIONES / OPTIONS

FINISHES / ACABADOS / FINITIONS

WOOD / MADERA / BOIS

WENGUE

CHERRY	CEREZO	MERISIER
OAK	ROBLE	CHÊNE
WALNUT	NOGAL	NOYER

LAQUERED / LACADO / LAQUE

BLACK, WHITE, RED,	NEGRO, BLANCO, ROJO	NOIR, BLANC, ROUGE
STONE, GREY, SEA	PIEDRA, GRIS, MAR, VERDE	PIERRE, GREY, MER

GREEN, FUCHSIA, ORANGE	FUCSIA, NARANJA	VERT, FUCHSIA, ORANGE
------------------------	-----------------	-----------------------

SEE FINISHES TABLE ENCLOSED	VER TABLA DE ACABADOS	VOIR TABLEAU DES FINITIONS
-----------------------------	-----------------------	----------------------------



WOOD TAPE



CRYSTAL TAPE

REF.

WOOD TAPE



82810



82812

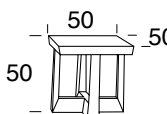

82860

CRYSTAL TAPE

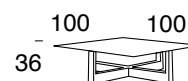

82811



82813

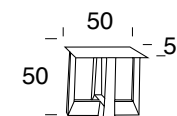

82861

OPTIONS / OPCIONES / OPTIONS

FINISHES / ACABADOS / FINITIONS

WALNUT NOGAL NOYER



REF.

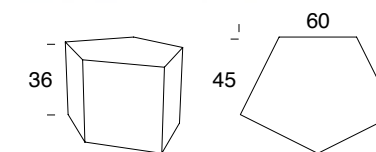

99230

OPTIONS / OPCIONES / OPTIONS

FINISHES / ACABADOS / FINITIONS

WOOD / MADERA / BOIS

WENGUE

CHERRY	CEREZO	MERISIER
OAK	ROBLE	CHÊNE
WALNUT	NOGAL	NOYER

LAQUERED / LACADO / LAQUE

BLACK, WHITE, RED,	NEGRO, BLANCO, ROJO	NOIR, BLANC, ROUGE
STONE, GREY, SEA	PIEDRA, GRIS, MAR, VERDE	PIERRE, GREY, MER

GREEN, FUCHSIA, ORANGE	FUCSIA, NARANJA	VERT, FUCHSIA, ORANGE
------------------------	-----------------	-----------------------

SEE FINISHES TABLE ENCLOSED	VER TABLA DE ACABADOS	VOIR TABLEAU DES FINITIONS
-----------------------------	-----------------------	----------------------------



REF.



83479



83459



83448

OPTIONS / OPCIONES / OPTIONS

FINISHES / ACABADOS / FINITIONS

WOOD / MADERA / BOIS

WENGUE

CHERRY	CEREZO	MERISIER
OAK	ROBLE	CHÊNE
WALNUT	NOGAL	NOYER

LAQUERED / LACADO / LAQUE

BLACK, WHITE, RED,	NEGRO, BLANCO, ROJO	NOIR, BLANC, ROUGE
STONE, GREY, SEA	PIEDRA, GRIS, MAR, VERDE	PIERRE, GREY, MER

GREEN, FUCHSIA, ORANGE	FUCSIA, NARANJA	VERT, FUCHSIA, ORANGE
------------------------	-----------------	-----------------------

SEE FINISHES TABLE ENCLOSED	VER TABLA DE ACABADOS	VOIR TABLEAU DES FINITIONS
-----------------------------	-----------------------	----------------------------

Some of our Projects

Hotels

PARK MAXIMILIAM, REGENSBURG.....	ALEMANIA
HOTEL L'AQUARIUM.....	ARGELIA
RESIDENCE MRAGUEN ADRAR.....	ARGELIA
HOTEL SOL Y MAR, CALPE.....	ALICANTE
ALBIR HILL RESORTS.....	EL ALBIR (ALICANTE)
HOTEL QUINO.....	GUARDAMAR (ALICANTE)
INDALA GARDEN.....	ALMERÍA
HOTEL MERIDA PALACE.....	BADAJOS
AC-MARRIOT.....	BARCELONA
AC NOVOTEL SANT CUGAT.....	BARCELONA
FIESTA HOTEL AYRE ROSELLÓ.....	BARCELONA
HOTEL ANDANTE.....	BARCELONA
HOTEL VINCCI GALA - BCN.....	BARCELONA
ANGLI BONANOVA.....	BARCELONA
EUROSTAR GAUDI.....	BARCELONA
EUROSTAR RAMBLA BOQUERÍA.....	BARCELONA
HIGH TECH.....	BARCELONA
AC-MARRIOT JEREZ DE LA FRONTERA.....	CADIZ
MELÍA.....	CÁDIZ
ALBORAN.....	CHICLANA (CÁDIZ)
TRYP HOTEL LOS GALLOS.....	CORDOBA
VINCCI.....	GRANADA
PUNTA EUROPA.....	HUELVA
HOTEL HARD ROCK.....	IBIZA
USHUAIA TOWER.....	IBIZA
FIESTA CALA GRACIOSA.....	IBIZA
FIESTA CALA LONGA.....	IBIZA
FIESTA DON CARLOS.....	IBIZA
SIRENIS AURA.....	IBIZA
SIRENIS ATLANTIS.....	IBIZA
SIRENIS CLUB SIESTA.....	IBIZA
SIRENIS GOLETA.....	IBIZA
SIRENIS TRES CARABELAS.....	IBIZA
AC-MARRIOT GENOVA.....	ITALIA
AC-MARRIOT VICENZA.....	ITALIA
RESORT CLUB LA SANTA.....	LANZAROTE
HOTEL FARIONES.....	LANZAROTE
DIAMAR.....	LANZAROTE
AC-MARRIOT LAS PALMAS.....	LAS PALMAS
HOTEL EDEN AMADORES.....	LAS PALMAS
CASERIOHOTEL.....	LAS PALMAS
HOTEL BALITO BEACH.....	LAS PALMAS
HOTEL PUERTO AZUL AMADORES.....	LAS PALMAS
HOTEL "ONLY YOU" AYRE BARQUILLO.....	MADRID
AC MARRIOT CUZCO.....	MADRID
AC MARRIOT LA FINCA, POZUELO.....	MADRID
AC HOTEL PARQUE DEL RETIRO.....	MADRID
LINCE HOTEL.....	MADRID
ROOM MATE MARIO.....	MADRID
NH HOTEL.....	MADRID
VINCCI.....	MADRID
HOTEL VINCCI.....	MÁLAGA
ROOM MATE LARIOS.....	MÁLAGA
HIGH TECH PLAZA.....	MÁLAGA
SUNWING RESORT ALCUDIA.....	MALLORCA
BQ HOTELS.....	PALMA DE MALLORCA
CASA DEL ABAD AMPUDIA.....	PALENCIA
HOTEL VENECIA.....	SEVILLA
SILKEN AL-ANDALUS PALACE.....	SEVILLA
AUGUSTA SPA RESORT.....	SANXENSO, (PONTEVEDRA)
MASS PASSAMANER.....	TARRAGONA
FELIPE IV, HOTEL.....	VALLADOLID
ZENIT DON YO.....	ZARAGOZA
AC HOTEL NICE.....	FRANCIA
EUROSTAR PANORAMA PARÍS.....	FRANCIA
HOTEL DOMINIQUE COLONNA CORSE.....	FRANCIA
FIESTA GRAND PALLADIUM LADY HAMILTON.....	JAMAICA
HOTEL OMEYA, TETUAN.....	MARRUECOS
ATLAS HOSPITALITY.....	CASABLANCA (MARRUECOS)
HOTEL GRAND PALLADIUM RIVIERA MAYA.....	MEXICO
FIESTA PRIMA FREE TRADE.....	CANCÚN, (MÉXICO)

SIRENIS RIVIERA MAYA.....	RIVIERA MAYA, (MEXICO)
BILLAR PEARL SUITES.....	QATAR
MAJLIS.....	DOHA (QATAR)
EUROSTAR DAVID.....	PRAGA (REP. CHECA)
EUROSTAR THALIA.....	PRAGA (REP. CHECA)
HOTEL GRAND PALLADIUM BAVARO, PUNTA CANA.....	REP. DOMINICANA
VILA MIZZUMI, CONSTANTA.....	RUMANIA

Apartments

COLINA INVEST.....	CALPE (ALICANTE)
IMPERIAL PARK.....	CALPE (ALICANTE)
APARTAMENTOS RISCO DEL GATO.....	FUERTEVENTURA
APARTAMENTOS LOS FICUS.....	LANZAROTE
APARTAMENTOS EL TREBOL.....	LANZAROTE
COSTA SAL.....	LANZAROTE (LAS PALMAS)
LANZASUR.....	LANZAROTE (LAS PALMAS)
LA LLOVIZNA.....	LANZAROTE (LAS PALMAS)
PARTAMENTOS MORASOL.....	LAS PALMAS
APARTAMENTOS CASA MAR Y CASA MONTE.....	LAS PALMAS
OL AMADORES.....	LAS PALMAS
TISALAYA.....	LAS PALMAS
APARTAMENTOS JANDIA MARINA.....	FUERTEVENTURA (LAS PALMAS)
URBANIZACIÓN COSTA DE VERA.....	AGUILAS (MURCIA)
PROMOCIONES FULGENCIO CUTILLAS.....	MOLINA DEL SEGURA (MURCIA)
CASABLANCA.....	MARRUECOS

Restaurants

LA CHAMPAGNERIA.....	CALPE (ALICANTE)
CAVIAR, RESTAURANTE.....	CALPE (ALICANTE)
ELÍGEME, CAFETERÍA Y PASTELERÍA.....	GUARDAMAR (ALICANTE)
HARD ROCK CAFE IBIZA.....	IBIZA
SA BRISA GASTRO BAR.....	IBIZA
RESTAURANTE EN FUENGIROLA.....	MÁLAGA
MANGROVIA DELICE FOOD.....	MILÁN (ITALIA)

Medicals Centers, Shopping Centers, Office, Airports, Railwail Stations and others

SALA VIP CENTRO COMERCIAL PYRINEES.....	ANDORRA
ZAIN, OFICINAS TELÉFONOS.....	ARABIA SAUDÍ
BRAEHEAD SHOPPING CENTER, GLASGOW.....	ENGLAND
LAKESIDE SHOPPING CENTER, GATESHEAD.....	ENGLAND
METROCENTER SHOPPING CENTER, ESSEX.....	ENGLAND
WATFORD SHOPPING CENTER, HERTFORDSHIRE.....	ENGLAND
ELDON SQUARE SHOPPING CENTER, NEWCASTLE.....	ENGLAND
POTTERIES SHOPPING CENTER, NOTTINGHAM.....	ENGLAND
VICTORIA CENTER SHOPPING CENTER, KENT.....	ENGLAND
CHAPELFIELD SHOPPING CENTER, NORWICH.....	ENGLAND
BROADMARSH SHOPPING CENTER, NOTTINGHAMSHIRE.....	ENGLAND
UXBRIDGE SHOPPING CENTER, GREATER LONDON.....	ENGLAND
ING DIRECT OFICINAS.....	ESPAÑA
CLÍNICA BAVIERA.....	ESPAÑA Y ALEMANÍA
SALA VIP, ESTACIÓN AVE MADRID-ALBACETE.....	ALBACETE
JARDINES DEL EDEN, RESIDENCIA.....	ALICANTE
CENTRO DE SALUD.....	BUSOT (ALICANTE)
CLÍNICA ORTODONCIA.....	BENIDORM (ALICANTE)
COCEMFE, RESIDENCIA GERIÁTRICA.....	PETREER (ALICANTE)
SALA VIP ESTACION AVE ALICANTE.....	ALICANTE
AENA, SALA VIP AEROPUERTO BADAJOZ.....	BADAJOS
SALA VIP ESTACION AVE BARCELONA.....	BARCELONA
SALA VIP ESTACION AVE GERONA.....	GERONA
CIUDAD DEPORTIVA REAL MADRID, VALDEBEBAS.....	MADRID
SALA VIP ESTACION AVE CHAMARTÍN.....	MADRID
AENA, SALA VIP AEROPUERTO MADRID.....	MADRID
SALAS VIP AEROPUERTO.....	MADRID
RESIDENCIA BUCHINGER.....	MÁLAGA
FRAJUMAR, OFICINAS.....	MURCIA
AEROPUERTO.....	SANTIAGO
CASINO.....	TENERIFE
CENTRO COMERCIAL VALLSUR.....	VALLADOLID
SALA VIP, ESTACIÓN AVE VALENCIA.....	VALENCIA
OFICINAS COCEMFE VALENCIA.....	VALENCIA
GREFUSA, OFICINAS.....	VALENCIA
CULTURALIS BURGEAUD EQUIP. BIBLIOTECA.....	PORTUGAL
CENTRO MEDICO GERMANO DE SOUSA.....	PORTUGAL

Beltá & Frajumar Projects is a furniture and upholstery manufacturer and we offer a wide range of services in order to achieve any kind of integral project for interior design at domestic and international markets, proven through all of the projects accomplished. We act as the sole negotiator with our customer. We work with private customers, hotels, architects, interior designers, decorative artists and the public sector. We have a wide knowledge of the manufacturing process and a large experience working with new raw materials. We also have a professional assembling team which allows us to offer to the customer a "turnkey" project if required. We have an excellent technical and commercial department. This is the reason we can achieve any project, always offering our customers a final product with high quality standards, high and competitive value and important cost saving.

Many projects around the world have been accomplished by us or are equipped with our products. You can get more information in our website www.beltafrajumar.com

Beltá & Frajumar Projects como fabricante de muebles y tapizados, ofrece un amplio abanico de servicios adicionales para realizar todo tipo de proyectos integrales de interiorismo a escala nacional e internacional, avalada por cada uno de los proyectos realizados. Actuamos como único interlocutor con nuestro cliente. Trabajamos con clientes particulares, hoteles, arquitectos, interioristas, decoradores y empresas públicas. Tenemos un amplio conocimiento de los procesos productivos además de una gran experiencia en el manejo de materiales; y disponemos de un equipo de montadores profesionales que nos permiten realizar proyectos "llave en mano" si el cliente así lo necesita. Contamos con un excelente departamento técnico y comercial, todo ello nos permite abordar cualquier tipo de proyecto ofreciendo siempre a nuestros clientes un producto final impecable otorgando al mismo un alto valor competitivo y un importante ahorro en costes.

Muchos proyectos en todo el mundo han sido realizados por nosotros o están equipados con nuestros productos. Podrá ampliar esta información en la web www.beltafrajumar.com



SOL Y MAR HOTEL, CALPE, SPAIN.



TRYP HOTEL, CORDOBA.



HARD ROCK HOTEL, IBIZA.



VINCCI GALA, BARCELONA.



USHUAIA TOWER, IBIZA.



ONLY YOU HOTEL, MADRID.



ONLY YOU HOTEL, MADRID.

Showroom

You are invited to visit our factory and showroom in Yecla, where you will find :

.Showroom for Home products. You will see almost all of our products.

.Showroom for Contract. You will see different Hotel room styles, Restaurants, Lobbies.

Real products where you can touch the quality of the product and assembly.

To Schedule a visit, please send an inquiry to info@betafrajumar.com or call: **0034 968 719 111**.

Le invitamos a que nos visite en nuestras instalaciones en Yecla, Murcia, donde disponemos de dos espacios de exposición:

.Showroom Hogar, donde se muestra la mayoría de los productos de nuestra colección.

.Showroom Contract, donde puede ver diferentes estilos de Habitaciones de Hotel, Restaurantes - Cafeterías, Lobbies.

Espacios reales donde puede comprobar la calidad de nuestros productos y montajes.

*Para visitarnos, concierte una cita previa a través del email info@betafrajumar.com o en el tlf: **0034 968 719111**.*



We invite you to visit our websites where you can get more information.

It's an update portal with news, projects, catalogues, products, fabrics, finishes, pricelist, 3d files, etc...

Download our multimedia catalogue for the iPad, with important advantages, always updating and replacing the print catalogue. You can follow us in Facebook, Twitter, Pinterest and Youtube.

Les invitamos a visitar nuestras webs. Un espacio donde podrán tener toda la información de un modo rápido e intuitivo.

Una herramienta actualizada con noticias, proyectos, catálogos, productos, tejidos, acabados, tarifas, archivos 3D y mucho más.

Descarga nuestro catálogo multimedia para iPad, con importantes ventajas, siempre actualizado y sustituyendo los pesados catálogos. También puede seguirnos en Facebook, Twitter, Pinterest y Youtube.



Environmental Policy. ISO 14001.

Beltá is firmly committed to protecting and caring for the environment. All the environmental objectives that are to be fulfilled by the organisation are coordinated in an Environmental Management Policy, drawn up and approved within the company. In short, Beltá aims to be a leading company in design, quality and service, implementing simple, low-bureaucracy company management policies, and fostering human and social relationships as much as possible, whilst caring for and protecting the environment.

The FOUNDATION SPANISH WOOD certifies us as a company committed to good practices Ecoinnovation through prototype development based on Ecodesign.



Política Medio Ambiental. ISO 14001.

Beltá está firmemente comprometida con el cuidado y protección del medioambiente y coordina a través de la aprobación de una Política de Gestión Ambiental todos los objetivos y líneas estratégicas ambientales a cumplir por la organización. Es por ello que Beltá, como firma comprometida con la ecología, únicamente trabaja con madera de bosques gestionados para cumplir las necesidades sociales, económicas y ambientalmente responsables de generaciones futuras.

La FUNDACIÓN ESPAÑOLA DE LA MADERA nos certifica como empresa comprometida con buenas prácticas en materia de Ecoinnovación a través del desarrollo de prototipo basados en Ecodiseño.



Awards and Recognition

- 2012** 1st Prize International Furniture Industrial Design of CETEM contest, TOUPIE, by Nieves Contreras.
- 2011** Finalist Delta Awards ADI FAD. PLAY, by Jorge Pensi.
- 2007** 3rd Prize International Furniture Industrial Design of CETEM contest, Stanza by Yonoh.
- 2005** Enterprise Innovation Award, granted by Murcia County Promotion Institute.
- 2005** 1st & 2nd Prize International Furniture Industrial Design of CETEM contest, Nomi and Gica by Eduardo Climent.
- 2005** Web Initiative Award for Internet Electronic Business, granted by TIMUR.
- 2004** Finalist Compasso d'Oro Award, Milano (Italy). Onda by Diego Granese.
- 2003** cDIM 2003 Award. FIM, Furniture Fair of Valencia.
- 2002** Mercurio Award, granted by Chamber of Commerce.
- 2001** 1st Prize International Furniture CETEM contest, XK-8.
- 2001** 3rd Prize Furniture Design CETEM contest, INSIDE.



Premios y Galardones

- 2012 1º Premio Concurso Internacional del Mueble de CETEM. TOUPIE, diseñado por Nieves Contreras.
- 2011 Finalista Premios Delta ADI FAD. PLAY por Jorge Pensi.
- 2007 3º Premio Concurso Internacional del Mueble de CETEM. STANZA diseñado por Yonoh.
- 2005 Premio de Innovación Empresarial, entregado por el Instituto de Fomento de la Región de Murcia.
- 2005 1º y 2º Premio Concurso Internacional del Mueble de CETEM. Nomi y Gica diseñado por Eduardo Climent.
- 2005 Premio a Iniciativa Web de Negocio Electrónico en Internet entregado por TIMUR.
- 2004 Finalista Premio Compasso d'Oro, Milan (Italia). Onda diseñada por Diego Granese.
- 2003 cDIM 2003 Award. FIM, Furniture Fair of Valencia.
- 2002 Premio Mercurio, entregado por la Cámara de Comercio.
- 2001 1º Premio Concurso Internacional del Mueble de CETEM. XK-8.
- 2001 3º Premio Concurso del Mueble de CETEM, INSIDE.



Quality Standards

We test materials to ensure they meet the highest quality standards, safety, strength, and durability.

ISO 9001 QUALITY CERTIFICATE TO FRAJUMAR.

MATERIALS CERTIFICATES

SUSPENSION

.Nea webbing. 10 year guarantee.

FOAM

.Flamability Certificate 25 CMHR (Eupen).

.Flamability Certificate 35CMHRP1-08.

.Flamability Certificate CMHR 3030.

FABRICS

.Flamability Certificate DIN 4102-1, B1- Ambu.

.Flamability Certificate DIN 4102-1, B1- Bikar.

.Flamability Certificate DIN 4102-1, B1- Cres.

.Flamability Certificate DIN 4102-1, B1- Hainan.

.Flamability Certificate DIN 4102-1, B1- Honsu.

.Flamability Certificate DIN 4102-1, B1- Keros.

WASHING

. Staining and cleaning test (blood).

Download Quality information in PDF format at

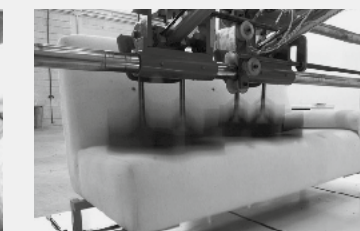

Normas de Calidad

Ponemos a prueba los materiales para garantizar que cumplen los más altos estándares de calidad, seguridad, resistencia y durabilidad

ISO 9001 CERTIFICADO DE CALIDAD FRAJUMAR.

CERTIFICADOS DE MATERIALES

SUSPENSIÓN

.Cinchas Nea. 10 años de Garantía.

ESPUMA

.Flamability Certificate 25 CMHR (Eupen).

.Flamability Certificate 35CMHRP1-08.

.Flamability Certificate CMHR 3030.

TEJIDOS

.Flamability Certificate DIN 4102-1, B1- Ambu.

.Flamability Certificate DIN 4102-1, B1- Bikar.

.Flamability Certificate DIN 4102-1, B1- Cres.

.Flamability Certificate DIN 4102-1, B1- Hainan.

.Flamability Certificate DIN 4102-1, B1- Honsu.

.Flamability Certificate DIN 4102-1, B1- Keros.

LIMPIEZA

. Staining and cleaning test (blood).

Descarga en PDF la información de Calidad en

MIKE INTERiÖR
ALLT INOM OFFENTLIG MILJÖ